

# User Manual

## Vacuklav 41 B+ Evolution Vacuklav 43 B+ Evolution

Steam sterilizer

as of software version v3.218



**EN**

Dear doctor,

We thank you for your confidence demonstrated by the purchase of this MELAG product. As an owner-run and operated family concern founded in 1951, we have a long history of successful specialization in hygiene products for practice-based use. Our focus on innovation, quality and the highest standards of operational reliability has established MELAG as the world's leading manufacturer in the instrument treatment and hygiene field.

You, our customer are justified in your demand for the best products, quality and reliability. Providing "**competence in hygiene**" and "**Quality – made in Germany**", we guarantee that these demands will be met. Our certified quality management system in accordance with ISO 13485 and ISO 9001 is subject to close monitoring e.g. through our annual multi-day audit conducted by a specified independent certification agency. This guarantees that all MELAG products are manufactured and tested in accordance with strict quality criteria.

The MELAG management and team.

CE 0197



# Contents

<b>1 General Guidelines</b> .....	<b>5</b>
Symbols used.....	5
Formatting rules.....	5
Symbols on the device.....	5
<b>2 Safety</b> .....	<b>7</b>
<b>3 Performance specifications</b> .....	<b>9</b>
Intended use .....	9
Sterilization procedure .....	9
Type of the feed water supply.....	9
Safety equipment.....	9
Overview of sterilization programs (class B).....	11
Program sequences.....	12
<b>4 Description of the device</b> .....	<b>13</b>
Scope of delivery.....	13
Views of the device.....	14
Energy-saving key.....	15
Load mounts.....	15
Colour-touch display.....	16
LED status bar.....	17
<b>5 First steps</b> .....	<b>18</b>
Setup and Installation.....	18
Feed water supply.....	18
Switching on the steam sterilizer.....	19
Opening and closing the door.....	19
<b>6 Loading the steam sterilizer</b> .....	<b>21</b>
Preparing the sterilization material.....	21
Loading the steam sterilizer.....	22
<b>7 Sterilization</b> .....	<b>24</b>
Important information regarding routine operation.....	24
Selecting the program.....	25
Additional program options.....	26
Starting the program.....	27
Program run.....	27
Manual program abort.....	28
Program end.....	30
Removing the sterilized equipment.....	31
Storing sterile instruments.....	32
<b>8 Logging</b> .....	<b>33</b>
Batch documentation.....	33
Output media.....	33
Outputting text logs automatically after program end (immediate output).....	35
Subsequent log output.....	36
Finding a log.....	38

<b>9 Functional checks</b> .....	<b>40</b>
Vacuum test .....	40
Bowie & Dick test .....	41
<b>10 Settings</b> .....	<b>42</b>
Logging .....	42
User administration .....	46
Formatting the CF card .....	48
Additional drying.....	48
Intelligent drying .....	49
Water supply .....	49
Date & time .....	50
Brightness .....	50
Volume .....	51
Key tone.....	51
Screensaver .....	52
Log printer MELAprint 42 .....	53
Label printer MELAprint 60 .....	53
Sensitivity .....	53
Energy-saving mode .....	53
<b>11 Maintenance</b> .....	<b>55</b>
Servicing intervals .....	55
Cleaning .....	55
Avoiding staining .....	57
Oiling the door spindle .....	57
Maintenance.....	58
<b>12 Pause times</b> .....	<b>59</b>
Frequency of sterilization .....	59
Decommissioning .....	59
Emptying the double jacket .....	59
Transport.....	60
Recommissioning after relocation .....	61
<b>13 Malfunctions</b> .....	<b>62</b>
Messages .....	62
Warnings .....	63
Malfunction messages .....	63
<b>14 Technical data</b> .....	<b>65</b>
<b>15 Accessories and spare parts</b> .....	<b>66</b>
<b>Glossary</b> .....	<b>67</b>



# 1 General Guidelines

Please read this user manual carefully before commissioning the device. The user manual includes important safety information. The functionality and value-retention of this device depends on the care accorded to it. Please store these user manual carefully and in close proximity to your device. It represents a component of the product.

Should the user manual no longer be legible, damaged or lost, please obtain a new copy from MELAG. State the device type and your address in an e-mail.

The device type is specified on the type plate on the rear of the device.

## Symbols used

Symbol	Explanation
	Indicates a dangerous situation, which if not avoided, could entail slight to life-threatening injuries.
	Draws your attention to a situation, which if not avoided, could result in damage to the instruments, the practice fittings or the device.
	Draws your attention to important information.

## Formatting rules

Example	Explanation
see <a href="#">Chapter 2</a>	Reference to another text section within this document
Settings	Words or phrases appearing on the display of the device are marked as display text.

## Symbols on the device



Manufacturer of the medical device



Date of manufacture of the medical device



Medical device serial number from the manufacturer



Article number of the medical device



Information about the chamber volume



Operating temperature of the device



Operating pressure of the device



The user manual includes important safety information. Failure to comply with these instructions can result in injury and material damage.



Please read this user manual carefully before commissioning the device.



In affixing this CE mark, the manufacturer declares that this medical product fulfils the basic requirements of the Medical products directive. The four-digit number confirms that this is monitored by an approved certification agency.



In affixing this CE mark, the manufacturer declares that this medical product fulfils the basic requirements of the Pressure equipment directive. The four-digit number confirms that this is monitored by an approved certification agency.



Draws your attention to a hot surface. Should the fan fail, the cooling unit fins can become hot.



The device may not be disposed as domestic waste. The vendor is responsible for appropriate disposal of the device - it must be delivered to the vendor to be disposed of. In affixing this symbol, the manufacturer furthermore declares that he has satisfied all the legal requirements pertaining to the release, redemption and environmentally sound disposal of electric and electronic appliances. MELAG devices are synonymous for long-term quality. When you eventually need to decommission your MELAG device, we offer a special disposal service. Simply contact your stockist.

## 2 Safety

---



When operating the device, comply with the following safety instructions as well as those contained in subsequent chapters. Use the device only for the purpose specified in these instructions. Failure to comply with the specifications of the safety instructions can result in injury and/or damage to the device.

### Qualified personnel

- As with the preceding instrument decontamination, the sterilization of instruments and textiles using this steam sterilizer may only be carried out by competent personnel.

### Set-up installation and commissioning

- Check the device for any damage suffered during transport after unpacking.
- Only have the device set up, installed, and started up by people authorized by MELAG.
- The connections for electrical provision and water supply and discharge must be set-up by trained personnel.
- In accordance with current VDE specifications, the device is unsuitable for operation in explosive atmospheres.
- The device is conceived for use outside patient surroundings. The device should be located at least 1.5 m away (radius) from the treatment area.
- The documentation media (computer, CF card reader etc.) must be placed in such a way that they cannot come into contact with liquids.
- Observe all the information contained in the technical manual during commissioning.

### Power cable and power plug

- Only the power cable included in the scope of delivery may be connected to the device.
- The power cable may not be replaced by a cable determined to be insufficient.
- Comply with all legal requirements and locally-specified connection conditions.
- Never operate the device if the plug or power cable are damaged.
- The power cable and plug should only be replaced by authorized personnel.
- Never damage or alter the power plug or cable.
- Never unplug by pulling on the power cable. Always take a grip on the plug.
- Ensure that the power cable does not become jammed in.
- Never lead the cable along a source of heat.
- Never fix the power cable with sharp objects.

### Double-jacket steam generator

- The steam sterilizer remains pressurized for a long time after being switched-off. Check the pressure display of the manometer below on the front of the device.

### Decontamination and sterilization

- Follow the manufacturer instructions of your textile articles and instruments regarding their decontamination and sterilization.
- Observe the relevant standards and directives for the decontamination and sterilization of textiles and instruments, e.g. RKI [Robert Koch Institute] and DGSV [German Society for Sterile Supply].
- Only ever use packaging material and systems which have been approved by their manufacturer for steam sterilization (consult the manufacturer's instructions).

### Program termination

- Please observe that depending on the time of the program abort, opening the door following a program abort can lead to hot steam leaving the chamber.

- Depending on the time of the program abort, it is possible that the load is unsterile. Observe the clear instructions shown on the display of the steam sterilizer. If necessary, sterilize the affected objects after rewrapping.

**Removing the sterilized equipment**

- Never use force to open the door.
- Use a tray jack to remove the tray. Never touch the sterilized items, the chamber or the door with unprotected hands. The components are hot.
- Check the packaging on the sterilized equipment for damage when removing it from the steam sterilizer. Should the packaging be damaged, re-pack the sterilization material and re-sterilize it.

**Transport and storage**

- Install and operate the device in a frost-free environment.
- The device should always be carried by two people.
- Use suitable carrying straps to carry the device.

**Maintenance**

- Have the maintenance done only by authorized persons.
- Maintain the specified servicing intervals.
- Only original MELAG spare parts may be used.

**Malfunctions**

- Should the device issue the same malfunction message repeatedly, turn off the device and if necessary, inform your stockist.
- Only have the device repaired by authorized persons.



## 3 Performance specifications

---

### Intended use

This steam sterilizer is designed for application in a medical context, e.g. General Practitioners and dental practices. According to DIN EN 13060, this steam sterilizer is a Class B sterilizer. As a universal steam sterilizer, it is suited to highly-demanding sterilization tasks. It can be used to sterilize instruments with a narrow lumen and transfer instruments - both wrapped or unwrapped - and large quantities of textiles.



#### **WARNING**

**Any attempt to sterilize liquids can result in a delay in boiling. This can result in damage of the steam sterilizer and burns.**

- Never use this steam sterilizer to sterilize any fluids. It is not licensed for the sterilization of fluids.

### Sterilization procedure

The steam sterilizer sterilizes on the basis of the fractionated vacuum procedure. This guarantees the complete and effective wetting/penetration of the sterilization material with saturated steam.

This procedure enables the sterilization of loads common to a doctor's practice.

The steam sterilizer uses the double-jacket technology to generate the sterilization steam, i.e. the steam sterilizer is fitted with a separate steam generator combined with a double-walled sterilization chamber. After heating, steam is held constantly available in the double-jacket. This gives the walls of the sterilization chamber a defined temperature and protects the sterilization chamber from overheating. This especially effective procedure supports the quick evacuation of the air from the sterilization chamber, the sterilization packaging and instrument cavities. This permits the sterilization of large quantities of instruments or textiles directly one after each other, thereby achieving excellent drying results.

### Type of the feed water supply

The steam sterilizer works with a one-way feed water system. This means that it uses fresh feed water (i.e. demineralized or distilled water) for every sterilization procedure. The quality of the feed water is subject to permanent monitoring via integrated conductivity measurement. If combined with careful preparation of the instruments, this serves largely to prevent stain accretion on the instruments and soiling of the steam sterilizer.

### Safety equipment

#### **Internal process monitoring**

An process evaluation system is integrated in the electronics of the steam sterilizer. It compares the process parameters (such as temperature, time and pressure) during a program run. It monitors the parameters in terms of their threshold values during control and regulation and guarantees safe and successful sterilization. A monitoring system checks the device components of the steam sterilizer for their functionality and their plausible interaction. If one or more parameters exceeds pre-determined threshold values, the steam sterilizer issues warning or malfunction messages and if necessary, aborts the program. In the case of a program abort, follow the instructions on the display.

The steam sterilizer uses an electronic parameter control. This enables the steam sterilizer to optimize the total operating time of a program in dependence on the load.

#### **Door mechanism**

The steam sterilizer constantly checks pressure and temperature in the sterilization chamber and prevents the door from being opened when over-pressure has built up in the chamber. The motor-driven automatic door locking mechanism opens the door slowly by turning the locking spindle. This also holds the door

whilst it opens. Pressure compensation will have been performed by the time that the door is completely open, even following pressure differences.

***Quantity and quality of the feed water***

The quantity and quality of the feed water is automatically checked before every program start.

***Automatic emergency shutdown***

The steam sterilizer is equipped with an emergency shut-down mechanism; i.e. the steam sterilizer shuts down automatically if the internal process evaluation system registers a fault which represents a particular hazard situation. Reactivation of the steam sterilizer is only possible after the malfunction has been remedied.

## Overview of sterilization programs (class B)

The results in this table show which inspections were performed on the steam sterilizer. The marked field shows compliance with all the applicable sections of the standard DIN EN 13060.

Type tests	Universal-Program	Quick-Program B	Quick-Program S	Gentle-Program	Prion-Program
Program type in accordance with DIN EN 13060	Type B	Type B	Type S	Type B	Type B
Dynamic pressure test of the sterilization chamber	X	X	X	X	X
Air leakage	X	X	X	X	X
Empty chamber test	X	X	X	X	X
Solid load	X	X	X	X	X
Porous partial load	X	--	--	X	X
Porous full load	X	--	--	X	X
Simple hollow body (Hollow body B)	X	X	X	X	X
Product with narrow lumen (Hollow body A)	X	X	--	X	X
Single wrapping	X	X	--	X	X
Multiple wrapping	X	--	--	X	X
Drying solid load	X	X	X	X	X
Drying, porous load	X	--	--	X	X
Sterilization temperature	134 °C	134 °C	134 °C	121 °C	134 °C
Sterilization pressure	2.1 bar	2.1 bar	2.1 bar	1.1 bar	2.1 bar
Sterilization time	5:30 min.	5:30 min.	03:30 min.	20:30 min.	20:30 min.
X = Complies with all applicable sections of the standard DIN EN 13060					

## Program sequences

### **Regular sterilization program**

A program runs in three phases, the air removal; sterilization; and drying phase. After program start, you can follow the program run on the display. It shows the chamber temperature and pressure as well as the time until the end of sterilization / the drying.

Program phase	Description
1. The air removal phase (fractionation)	The air removal phase comprizes the conditioning and the evacuation phase. During conditioning, steam is repeatedly injected into the sterilization chamber to generate over-pressure. The mixture of air and steam is then removed repeatedly (evacuation). This procedure is also called the fractionated pre-vacuum procedure.
2. Heating phase	The heating phase follows the air removal phase. The continued steam admittance into the chamber leads to an increase in pressure and temperature which continues until the program-specific sterilization parameters have been reached.
3. Sterilization phase	If the pressure and temperature correspond to the program-dependent nominal values, the sterilization phase begins. The sterilization time is indicated on the display.
4. Pressure release	The end of the sterilization phase is followed by pressure release with simultaneous emptying of the steam generator.
5. Drying phase	The sterilization material is dried using a vacuum (vacuum drying). The drying phase begins after the pressure release. Upon program end, the chamber is filled with sterile air via the air filter and adjusted to the ambient pressure.
6. Ventilation	Once the program has come to an end, the chamber pressure is adapted to the ambient pressure. The corresponding display notification "ventilation" is displayed.

### **Vacuum test**

The vacuum test serves measurement of the leakage rate. No real sterilization is performed. The test is performed with a cold, dry and unloaded device.

Program phase	Description
1. Air removal phase (evacuation)	The chamber is evacuated until the pressure for the vacuum test has been reached.
2. Equilibration time	An equilibration time of five minutes will follow.
3. Measurement time	The measurement time amounts to ten minutes. The pressure increase within the chamber is measured during the measurement time. The evacuation pressure and the equilibration time or measuring times are shown on the display.
4. Test end	The display shows the test results, the batch number, the total number of batches and the leakage rate

## 4 Description of the device

---

### Scope of delivery

#### **Standard scope of delivery**

- Vacuklav 41 B+ or Vacuklav 43 B+
- User manual
- Usage instructions for the mounts
- Manufacturer's inspection report including declarations of conformity
- Guarantee
- Technical manual
- Record of installation and setup
- Mounts for trays and cassettes
- Tray lifter
- Power cable
- 2x cover caps for the fore device feet
- 2x mounts for the water treatment unit MELAdem
- 4x cover caps for niches for mounts in the side wall
- Allen key to open the door in an emergency
- TORX key for removing the carrying strap
- 1x hose for emptying the interior water storage tank
- Oil for door lock bushing

#### **Optional**

- Trays
- Standard tray cassettes and lifter
- MELAstore-Trays
- MELAstore-Boxes
- Additional mounts
- MELAflash CF card
- MELAflash CF card reader
- Wall bracket for Flex display

**Views of the device**

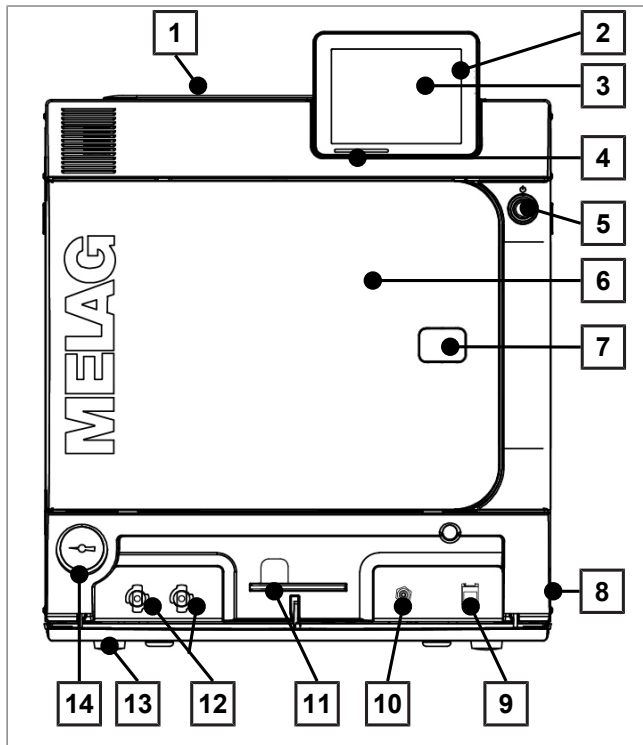

Fig. 1: View from front

- 1 Tank lid of the internal storage tank
  - 2 CF card slot
  - 3 Colour touch-display
  - 4 LED status bar
  - 5 Energy-saving key
  - 6 Door (swings open to the left)
  - 7 Opening for door opening in an emergency\*)
  - 8 Power switch (covered, accessible from the side)
  - 9 Ethernet connection
  - 10 Overheat control reset button
  - 11 Allen key 5 mm to open the door in an emergency
  - 12 Quick coupling for emptying the storage tank
  - 13 Front device foot (adjustable)
  - 14 Manometer for pressure display on the double-jacket steam generator\*)
- \*) behind cover

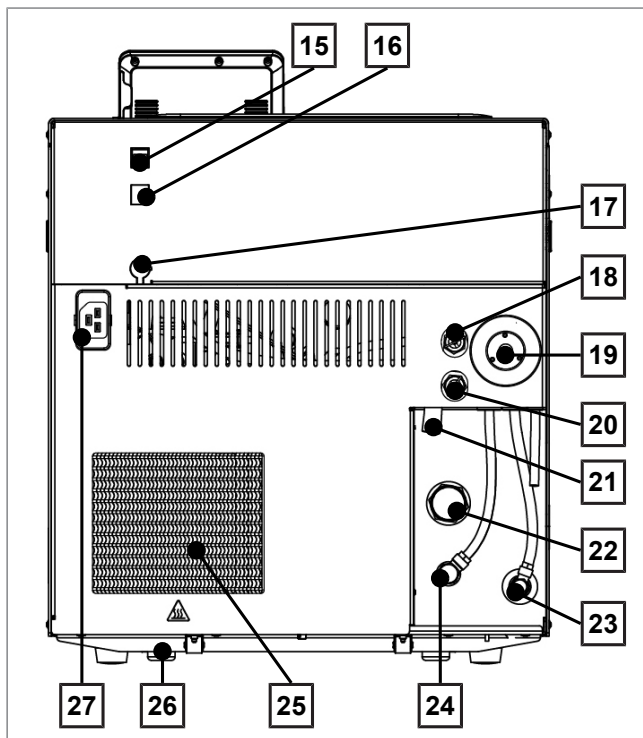
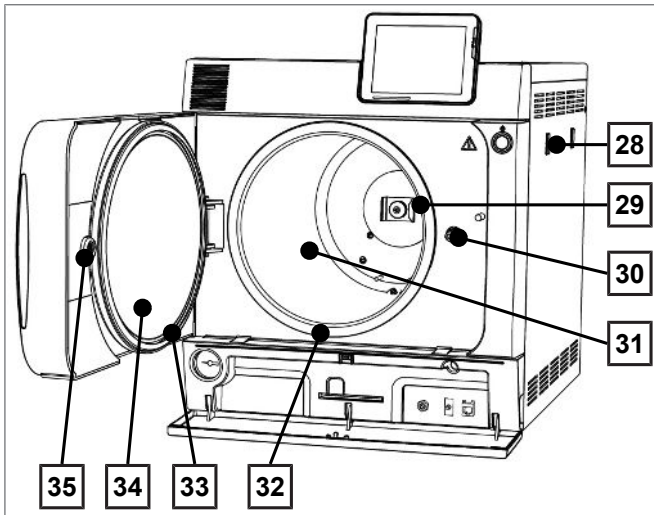

Fig. 2: View from rear

- 15 Ethernet connection
- 16 Ethernet connection, optional (upgradeable)
- 17 Optional connection of a Flex display
- 18 Spring safety valve chamber
- 19 Sterile filter
- 20 Spring safety valve double jacket
- 21 Emergency overflow
- 22 One-way discharge
- 23 Feed water inflow (swivel screw connection for Ø8x1 hose, alternative straight)
- 24 Connection pressure release
- 25 Cooler
- 26 Rear device foot (fixed)
- 27 Power cable connection



- 28 Mount for the water treatment unit MELAdem
- 29 Spring clip for fixing the mount "Plus"
- 30 Door spindle
- 31 Sterilization chamber
- 32 Chamber sealing face
- 33 Door seal
- 34 Round blank
- 35 Bushing

Fig. 3: View from front, door open

## Energy-saving key

Pressing the energy-saving key activates the energy-saving mode and switches off the display. The double jacket will not be heated until the next program start. This corresponds to waiting time 2, see also [Settings](#) [▶ page 42], [Energy-saving mode](#) [▶ page 53].

Pressing the energy-saving key again will switch the display back on.

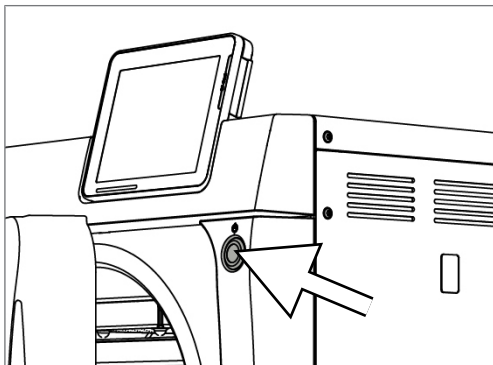

### NOTICE

The energy-saving mode can not be activated during a program run.

## Load mounts

The steam sterilizer is always delivered with a mount for holding trays or cassettes. Detailed information regarding the various mounts, their combinability with various load holders and their application can be found in the operating manual of the mounts

A spring clip is located on the rear panel of the sterilization chamber to fix the mount. When using a “Plus” mount, slide the mount into the sterilization chamber to its fullest extent, until the mount snaps into the spring clip.

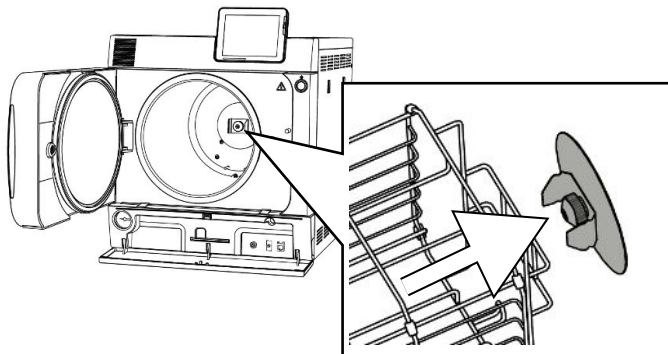



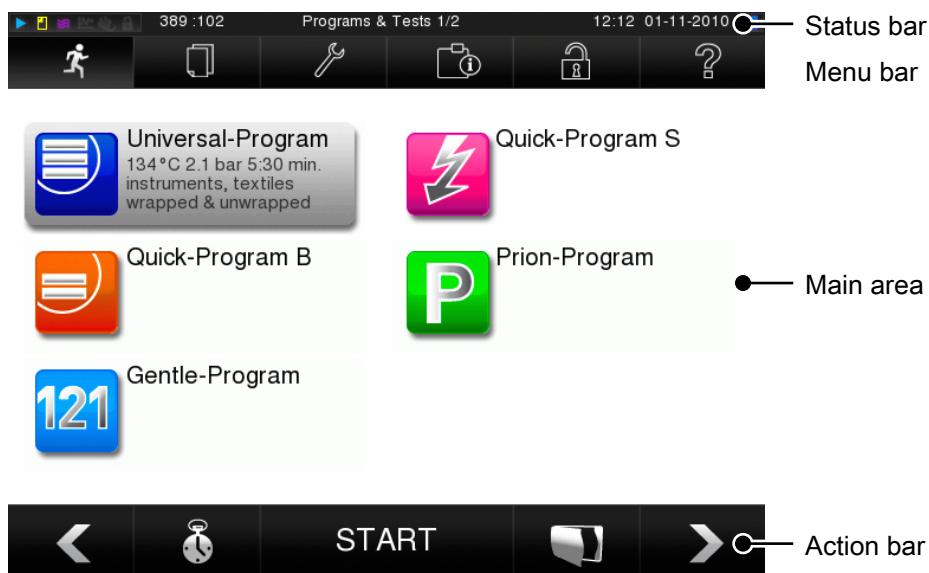

## Colour-touch display







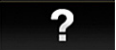

The operating panel consists of a colour 5 inch touch display.



Symbols in the status bar		Meaning
	Program/tests	Indicates whether a program/test is running
	Immediate output	Indicates whether immediate output is activated/deactivated
	Additional drying	Indicates whether additional drying is activated/deactivated
	Graphic logs	Indicates whether the graphic log recording is activated/deactivated
	Energy-saving mode	Indicates whether the steam sterilizer is currently in energy-saving mode
	Service area	Indicates whether a service technician is logged-in to the service area
	CF card status	Indicates whether a CF card has been inserted and whether a reading or writing action is in process.

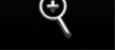

Symbol in the menu bar		Meaning
	Program/tests	Lists all sterilization programs and tests e.g. Vacuum test, Bowie & Dick- test etc.
	Log output	Here you can display the entire log list or the list of logs from a restricted time e.g. the day, month etc. You can also delete specific log types and logs.
	Settings	Here you can perform various settings such as date and time, brightness etc. It also enables one-time setting of the "standard" logging settings regarding log output.
	Info/status window	Displays information regarding the software version and device data e.g. total number of batches, maintenance counter, log settings, log memory and further technical values.
	Service area	Only for technicians
	Help menu	Depending on the window selected and the operating situation, gives information regarding operation or the function of the window currently selected.

Symbols in the action bar		Meaning
	Door open	Opens the door of the steam sterilizer
	Back	Returns to the previous window
	Forwards	Navigates to the next window
	Cancel/return without saving	Navigates to the superordinate menu, leaves the window without saving
	Zoom (+)	Displays further details such as further values after a completed program
	Start time pre-selection	Navigates to the "Start time pre-selection" menu
	Delete	Deletes logs from the internal log memory / deletes the log printer or label printer stored as standard
	Search	Searches for label printer(s)/log printer(s)

## LED status bar

The status bar on the lowest edge of the display indicates different situations with various colours

Colour of the LED	Meaning
Blue	Standby, program running, drying has not yet begun
Green	Drying running, program completed successfully
Yellow	Warning message, software update is running
Red	Malfunction message, program not completed successfully

## 5 First steps

### Setup and Installation



#### PLEASE NOTICE

Comply with the specifications of the technical manual during set-up and installation. This contains all building-side requirements.

#### *Record of installation and set-up*

The responsible stockist is to complete the record of installation and setup as proof of the correct setup, installation and commissioning. A copy is to be sent to MELAG Medizintechnik oHG and the stockist. This is a constituent part of any guarantee claim.

### Feed water supply

The steam sterilizer requires the use of distilled or demineralized water water, known as feed water. DIN EN 13060 requires that feed water be used in accordance with the guideline values in appendix C.

The steam sterilizer requires c. 3 L feed water for the first filling of the steam generator.

The feed water supply is effected either via the internal feed water tank or via a separate water treatment unit (e.g. MELAdem 40/MELAdem 47). The used feed water, so called waste water is either collected in the internal storage tank on the waste water side (left) and emptied manually or disposed of automatically via a building-side waste water connection.

#### Using the internal water storage container

The internal storage tank holds max. 5 litres. This volume of feed water is sufficient for up to 7 sterilization runs.

1. To fill the storage tank with fresh feed water remove the lid and fill the right-hand chamber of the storage tank with fresh feed water up to the MAX mark.

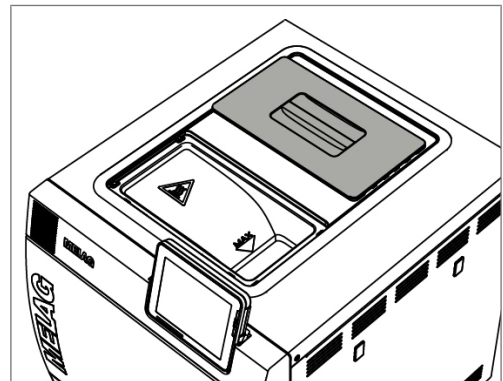

2. Set the feed water supply in the display to **INTERNAL**, see [Settings](#) [▶ page 42] ... Water supply.

## Switching on the steam sterilizer

- ✓ *The steam sterilizer is connected to the electricity supply.*
- ✓ *The feed water supply is secure. The steam sterilizer requires c. 3 L feed water for the first filling of the steam generator.*

1. Switch on the steam sterilizer at the power switch.

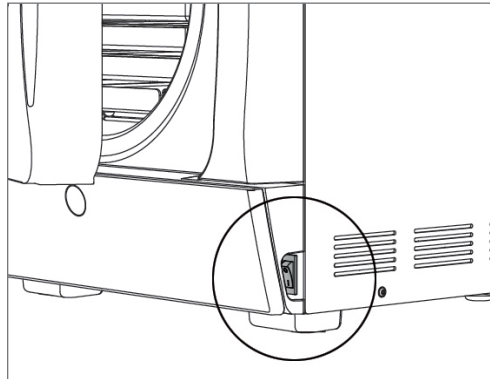

2. When the welcome screen appears, press CONTINUE. The display switches to the main menu.

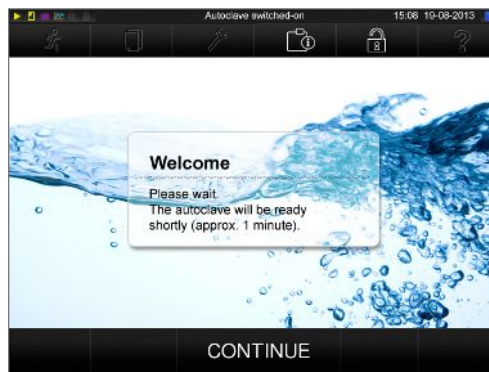

The feed water level is checked and pre-heated immediately after activation.

Depending on the device type, it requires a heat-up time of c. 9 - 13 minutes after being switched on. This time is required for the pre-heating of the double-jacket steam generator.

## Opening and closing the door

The steam sterilizer is fitted with a motor-driven automatic door locking mechanism with a threaded spindle. Entry on the display is only possible when the door is closed.

### Opening the door

The door is opened by pressing on the door symbol  on the display.

When opening the door, comply with the following instructions, so as to ensure faultless operation of the door locking mechanism.

- ▶ Never use force to open the door.
- ▶ Do not pull vigorously at the door to open it. The door opens automatically.



### PLEASE NOTICE

**The door is to be left open only whilst loading and unloading the steam sterilizer. Keeping the door closed saves energy.**

## Closing the door

To close the door, press it firmly inwards until the automatic door lock engages. After the door has been closed, the display returns to the program menu. The door is locked pressure-tight upon program start.

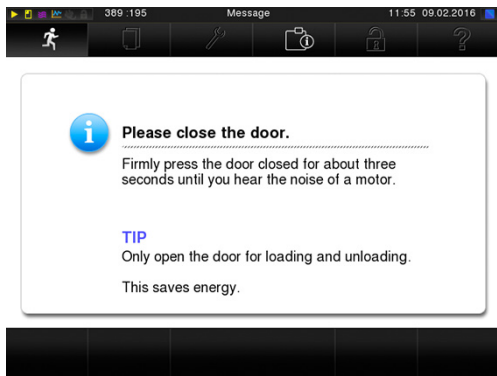

When closing the door, comply with the following instructions to guarantee faultless operation of the door locking mechanism:

- ▶ Do not exert too little pressure when pushing the door closed.
- ▶ Hold the door closed for min. 3 seconds until the door lock engages.
- ▶ Never slam the door.

## 6 Loading the steam sterilizer

---

### Preparing the sterilization material

Cleaning and disinfection must always have been performed before sterilization. Only in this way is it possible to guarantee the subsequent sterilization of the sterilization material. The materials used, the cleaning fluid and treatment procedures used are of decisive significance.

### Decontaminating the instruments

---



#### WARNING

The incorrect decontamination of instruments could result in any dirt residue being loosened by the steam pressure during sterilization.

The use of unsuitable care agents e.g. water repellent agents or oils impermeable to steam could result in unsterile instruments. This represents a danger to the health of both patients and yourself.

---



#### NOTICE

The presence of residual disinfection and cleaning fluids results in corrosion.

This could result in increased maintenance requirements and a restriction of the steam sterilizer function.

---

Please ensure the following when treating used and brand-new instruments:

- ▶ Follow both the instrument manufacturer's instructions regarding decontamination and sterilization and comply with the relevant standards and directives e.g. from the BGV A1, RKI and DGSV.
- ▶ Clean the instruments exceptionally thoroughly e.g. using an ultrasonic device or washer-disinfector.
- ▶ Rinse the instruments after washing and disinfecting, where possible with de-mineralized or distilled water and then dry the instruments thoroughly with a clean, non-fuzzing cloth.
- ▶ Use only those care agents suitable for steam sterilization. Consult the manufacturer of the care agents. Do not use any water repellent agents or oils impermeable to steam.
- ▶ When using ultrasound devices, care equipment for handpieces and washer-disinfectors, please comply with the manufacturer's treatment instructions.

### Treating textiles

---



#### WARNING

The incorrect decontamination of textiles, e.g. a textile package can prevent steam penetration and/or produce poor drying results. The textiles could not be sterilized.

This could endanger the health of patient and practice team.

---

Please comply with the following points when treating textiles and putting the textiles in sterilization containers:

- ▶ Comply with both the manufacturer's instructions of the textiles regarding treatment and sterilization as well as the relevant standards and directives e.g. from the RKI and DGSV.
- ▶ Arrange the folds in the textiles parallel to each other.
- ▶ Stack textiles vertically wherever possible and not too closely together in the sterilization container. This enables the development of flow channels.
- ▶ Retain the vertical stacking system when packing textiles in the sterilization container.

- ▶ If textile packages do not remain together, wrap the textiles in sterilization paper.
- ▶ Only ever sterilize dry textiles.
- ▶ The textiles may not be permitted to come into direct contact with the sterilization chamber; otherwise they will become saturated with condensate.

## Loading the steam sterilizer

Effective sterilization and good drying is only possible if the steam sterilizer has been loaded correctly.

Ensure the following during loading:

- ▶ Insert trays or cassettes in the chamber only with their appropriate mount.
- ▶ Use perforated trays such as those from MELAG. Only in this way can condensate drain off. The use of a non-perforated base or half-shell to accommodate the sterilization material can result in poor drying results.
- ▶ The use of paper tray inserts can also result in poor drying results.
- ▶ Wherever possible, please ensure the separate sterilization of textiles and instruments in separate sterilization containers or sterilization packaging. This leads to better drying results.

### Packaging

Only ever use packaging materials and systems (sterile barrier systems) which fulfil the standard DIN EN ISO 11607-1. The correct use of suitable packaging is important in achieving successful sterilization results. You can use re-usable rigid packaging systems such as e.g. standard tray cassettes or soft packaging such as transparent sterilization packaging, paper bags, sterilization paper, textiles or fleece.

## Closed sterilization containers



### CAUTION

**The use of unsuitable sterilization containers results in insufficient steam penetration and even failure of the sterilization. This can also prevent condensate drain-off.**

**This produces poor drying results. This can result in unsterile instruments and thus endanger the health of patient and practice team.**



### CAUTION

**Incorrect stacking of the sterilization containers can result in the dripping condensate being unable to drain off to the chamber floor. This can saturate sterilization material directly underneath it.**

**This produces poor drying results. This can result in unsterile instruments and thus endanger the health of patient and practice team.**

- Do not cover the perforations when stacking the sterilization containers.

Please comply with the following when using closed sterilization containers for sterilization material:

- ▶ Use aluminium sterilization containers. Aluminium retains and conducts heat and thus accelerates drying.
- ▶ Closed sterilization containers must be either perforated or have a valve on at least one side - optimally the bottom. MELAG sterilization containers fulfil the requirements for successful sterilization and drying.
- ▶ The perforations of one-sided perforated sterilization containers should be at the top of any containers as with MELAstore-Boxes.
- ▶ Wherever possible, please ensure that sterilization containers are only stacked on top of those of identical size, so that the condensate can run down their sides.
- ▶ Ensure that the perforations are not covered when stacking the containers.

## Soft sterilization packaging

Soft sterilization packaging can be used in both sterilization containers and on trays. Please comply with the following when using soft sterilization packaging e.g. MELAfol:

- ▶ Arrange soft sterilization packaging in a perpendicular position and at narrow intervals.
- ▶ Do not place multiple soft sterilization packages flat on top of each other on a tray or in a container.
- ▶ If the seam seal tears during sterilization, this could be caused by the choice of undersized packaging. Should this not be the case, re-pack the instruments and sterilize them again.
- ▶ Should the seam seal rip during sterilization, extend the sealing pulse on the film sealing device or make a double seam.

## Multiple wrapping

The steam sterilizer works with a fractionated vacuum procedure. This permits the use of multiple wrapping.

## Mixed loads

Please observe the following when sterilizing mixed loads

- ▶ Always place textiles at the top
- ▶ Place the sterilization containers at the bottom
- ▶ Place unwrapped instruments at the bottom
- ▶ Place the heaviest loads at the bottom
- ▶ Place transparent sterilization packaging and paper bags at the top - except in combination with textiles. In this case, place them at the bottom.
- ▶ Place transparent sterilization packages on their edge wherever possible and with the paper side facing downwards.

## 7 Sterilization

### Important information regarding routine operation

Please comply with the recommendations issued by the Robert-Koch-Institute (RKI) and the information contained in DIN 58946-7 (Germany).

#### *Manufacturer's recommendation for the routine operation of Class B steam sterilizers <sup>1</sup>*

When is it necessary to make checks?	How should the checks be made?
Once per working day	<ul style="list-style-type: none"> <li>▪ Visual check of the door seal and the door seal for damage.</li> <li>▪ Check the operating agents (electricity, feed water and water connection if necessary).</li> <li>▪ Check the documentation media (printer paper / computer / network)</li> </ul> <p>We recommend performing the steam penetration test with MELAcontrol/MELAcontrol PRO in the Universal-Program (test system in accordance with DIN EN 867-5).</p>
Once a week	<ul style="list-style-type: none"> <li>▪ Vacuum test</li> </ul> <p>Tip: In the mornings before starting work - the steam sterilizer must be cold and dry.</p>
Batch-related tests	<p>With "Critical B" instruments:</p> <ul style="list-style-type: none"> <li>▪ MELAcontrol/MELAcontrol PRO must be used as batch control with every sterilization cycle.</li> </ul> <p>With "Critical A" instruments:</p> <ul style="list-style-type: none"> <li>▪ The process indicator (type 5 in accordance with DIN EN ISO 11140) must be used as batch control with every sterilization cycle.</li> </ul> <p>With "Critical A + B" instruments:</p> <ul style="list-style-type: none"> <li>▪ MELAcontrol/MELAcontrol PRO must be used as batch control with every sterilization cycle.</li> </ul> <p>This simplifies the working procedure and increases security. You can omit the daily steam penetration test with MELAcontrol/MELAcontrol PRO (see above). The use of another test system in accordance with DIN EN 867-5 is possible. The number of the available test systems means that MELAG is not able to provide technical support when using a different system.</p>

The indicator test strips used need not be stored.



#### PLEASE NOTICE

The results of the tests must be documented.





<sup>1)</sup>in accordance with the current recommendations from the Robert-Koch-Institut







## Selecting the program

Now select the sterilization program according to how and whether the sterilization material is packed. It is also necessary to take into account the temperature resistance of the sterilization material. All sterilization and additional programs are displayed in the **Programs & Tests** menu. The following table shows which sterilization material fits which program and which additional programs are available.

	Universal-Program	Quick-Program B	Quick-Program S	Gentle-Program	Prion-Program
Sterilization temperature	134 °C	134 °C	134 °C	121 °C	134 °C
Sterilization pressure	2.1 bar	2.1 bar	2.1 bar	1.1 bar	2.1 bar
Sterilization time	5:30 min.	5:30 min.	03:30 min.	20:30 min.	20:30 min.
Operating time <sup>2</sup> Vacuklav 41 B+	c. 23 min.	c. 16 min.	c. 12 min.	c. 40 min.	c. 38 Min.
Operating time <sup>2)</sup> Vacuklav 43 B+	c. 25 min.	c. 16 min.	c. 13 min.	c. 42 min.	c. 39 min.
Intelligent drying	4 - 30 min.	4 - 30 min.	4 - 30 min.	4 - 30 min.	4 - 30 min.
Time-controlled drying	12 min.	c. 6 min.	c. 2 min.	12 Min.	12 Min.

Program name		Packaging	Especially suitable for	Load 41 B+/43 B+
Universal-Program		Single and multiple wrapping	Mixed load; long narrow-bore hollow bodies	6 kg/7 kg or 9 kg with MELAstore
Quick-Program B		Single wrapped and unwrapped instruments (no textiles)	Long narrow-bore hollow bodies	single wrapped max. 1.5 kg ----- unwrapped 6 kg/7 kg
Quick-Program S		Only unwrapped (no textiles)	Single massive instruments; transfer instruments; simple hollow bodies	6 kg/7 kg
Gentle-Program		Single and multiple wrapped	textiles; thermo-unstable items (e.g. plastic, rubber articles)	Textiles 2 kg/2.5 kg ----- Thermo-unstable equipment 6 kg/7 kg or 9 kg with MELAstore
Prion-Program		Single and multiple wrapped	instruments under suspicion of carrying the danger of infection through abnormally altered proteins (e.g. Creutzfeld-Jacob, BSE)	6 kg/7 kg or 9 kg with MELAstore

<sup>2)</sup> without drying with a full load and dependent upon the loading and setup conditions (such as the temperature of the cooling water, if fixed water connection present and the mains voltage)

Additional programs		Use/function
Vacuum test		For measuring the leakage rate, test with a dry and cold device (test without load)
Bowie & Dick test		Steam penetration test with special test package (available from specialist stockists)
Conductivity meas.		For manual measurement of the feed water quality
Draining		For emptying and pressure release of the double-jacket steam generator, e.g. for service, maintenance or before transport

## Additional program options

### Additional drying

Used with the types of load specified in this chapter, the program-specific drying times guarantee very good drying of the sterilized equipment. For difficult drying tasks you can activate the additional drying function retrospectively during a running program, see [Settings](#) [▶ page 42].

### Start time pre-selection



#### NOTICE

**Unsupervised operation of electrical devices, including this steam sterilizer at the operator's risk. MELAG accepts no liability what so ever for any damage resulting from unsupervised operation.**

This function enables you to select any program and start it at a time of your choice. The start time pre-selection is only active for the unique time and program selection. That means that after completion of the program, the pre-selected start time expires. You can switch-off the steam sterilizer during the start time pre-selection. However, the steam sterilizer must be switched on before the timer runs out.

Please note, the security query means that this function is not possible for Quick-Program S. To set a program start to a particular number, proceed as follows:

1. After selecting the program, press the  symbol in the action bar. The display switches to the settings window.



- For example, to change the time, tap directly on the parameters **Hour** or **Minutes**. The selected field is highlighted light blue.



- Change e.g. the hour by pressing the pushbuttons

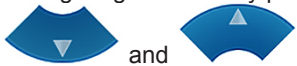

and

- Then press **START**. The display remains in the start time pre-selection window.

➔ After the start of the start time pre-selection no other menu apart from the Info & Status menu can be selected.

## Starting the program

With the start of the program, the door closes pressure-tight and the steam sterilizer checks the quantity of feed water and its conductivity.

- To start a program, press the **START** key.



### PLEASE NOTICE

When starting **Quick-Program S**, a warning and an acoustic signal indicates that this program only permits the sterilization of unwrapped instruments. If the load contains wrapped instruments only, confirm with **YES** to start the program.

## Program run

A program runs in three phases, the heating up and air removal phase, the sterilization phase and the drying phase. After program start, you can follow the program run on the display. It shows the chamber temperature and pressure as well as the time until the end of sterilization / the drying.

### Sterilization phase

The display enables you to see whether the sterilization phase has already been completed successfully. The coloured ring and the LED status bar switches from blue to green as soon as the drying phase has been introduced.

The sterilization phase is unsuccessful if the operator or the system (responding to a fault) aborts the program run. A system abort returns the steam sterilizer to a pressureless state. This explains why a system abort takes longer as an abort by the operator.

### Drying phase

The steam sterilizer provides excellent drying of the sterilization material. If difficult-to-dry items require better drying, you can undertake the following steps to improve drying:

- ▶ Load the steam sterilizer properly. Stand the transparent and paper sterilization packaging upright. Comply with the specifications of section [Loading the steam sterilizer](#) [▶ page 22]. Use the optional package holder if necessary.
- ▶ Activate the **Additional drying** function.

### Following the program run on the computer

You can follow the current progress of a sterilization program on every computer in the practice network.

✓ *The steam sterilizer has been assigned an IP address and is integrated in the practice network.*

1. Open a web browser (we recommend Mozilla Firefox or Internet Explorer) and enter the IP address of the steam sterilizer in the address bar of the web browser.
2. Confirm with [ENTER]. Now you can display the program run or information about your steam sterilizer (e.g. serial number, software version and selected values).

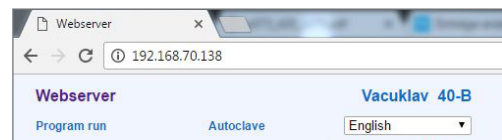

## Manual program abort

You can abort a current program in all phases. If you end the program before drying begins, the sterilization material remains **unsterile**.



### WARNING

Hot steam can be released from the device when opening the door after a program abort.

This could result in burns.

- Use a tray lifter to remove the tray.
- Never touch the sterilized equipment, the chamber or the door with bare hands. The components are hot.

## Program abort before the start of drying



### WARNING

Danger of infection from early program abort

Aborting a program before the drying phase begins means that the load is unsterile. This endangers the health of your patients and practice team.

- If necessary, repack the load and repeat the sterilization for the sterilization material affected.

Should you still wish to do so, proceed as follows to abort the program during drying:

1. Press CANCEL on the action bar.

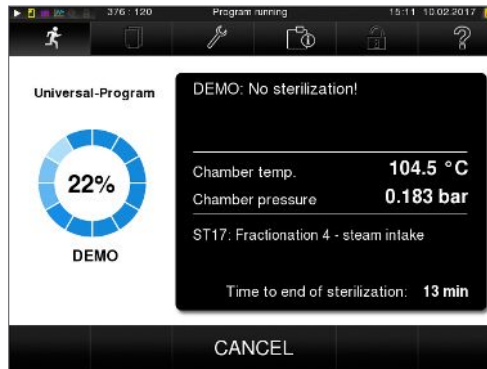

2. Confirm the security query with YES.

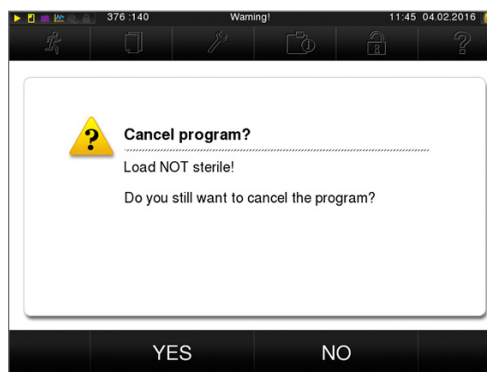

3. After a short time, you can open the door by pressing

the  symbol. The display shows a warning; the log records the sterilization as **NOT successful**.

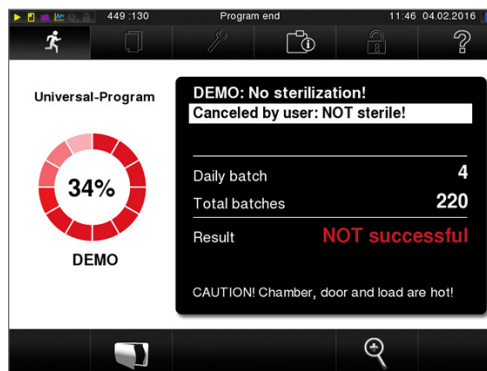

## Program abort after the start of drying

Should you abort a program after drying has started, the sterilization is having been completed successfully. The steam sterilizer issues a malfunction message. You then need to expect insufficient drying, especially in the case of wrapped sterilized equipment and a full load. Sterile storage requires sufficient drying. To ensure this, please allow programs with wrapped sterilized equipment to continue to the end of the drying phase as far as is possible. Unwrapped instruments sterilized in a Quick-Program dry after being removed from their own warmth.

Proceed as follows to abort the program during drying:

1. Press STOP on the action bar.



2. Confirm the security query with YES.

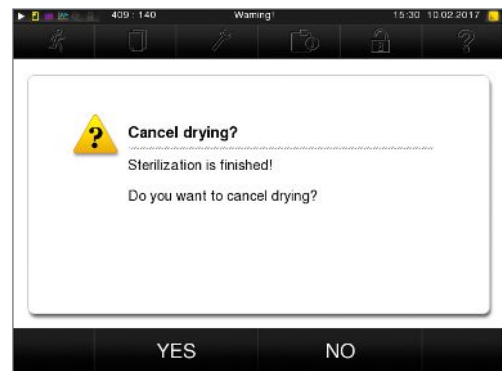

3. After a short time, you can open the door by pressing the door  symbol.

## Program end

When the program has ended successfully, the corresponding message will be issued on the display. Working in the **Settings** menu → **Logging** if immediate output after program end is activated, (= Immediate output), the log of the completed program will be outputted to the activated output medium after opening the door.

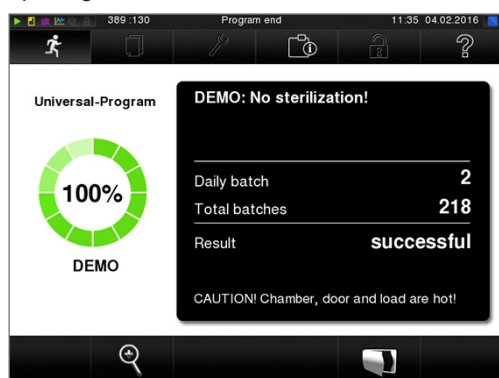

Before opening the door, you can view further values from the program which has just completed, e.g. the plateau time conductivity by pressing the magnifying glass symbol .

## The approval process

According to RKI "Hygiene requirements for the treatment of medical products", instrument treatment ends with the documented approval for storage and application of the sterilized equipment. The approval process consists of batch indication and batch approval and must be performed by authorized and expert personnel.

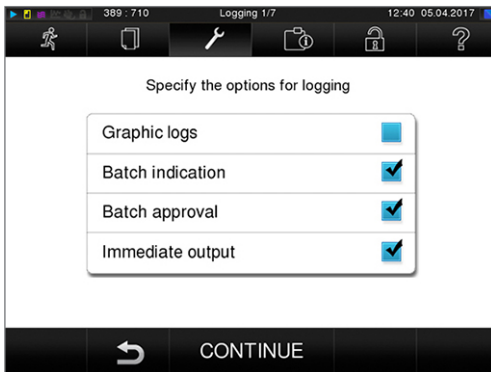

**Batch indication** comprises the checking of the indicators used in the sterilization program e.g. MELAcontrol/MELAcontrol PRO. Approval of the indicator strip is possible only if it changes colour entirely.

**Batch approval** comprises the checking of the process parameters using the sterilization results on the steam sterilizer and the sterilization log as well as checking of the individual packaging for damage and residual moisture. The sterilization log records the approval of the batch and any indicators. Depending on the setting in the user administration, approval for the sterilized equipment requires the user PIN of the person who provides approval for the batch and the indicators.

## Removing the sterilized equipment



### CAUTION

#### Danger of burns from hot metal surfaces

- Allow the device to cool sufficiently before opening.
- Do not touch any hot metal parts.



### CAUTION

#### Unsterile instruments resulting from damaged or burst packaging. This endangers the health of your patients and practice team.

- Should the packaging be damaged or have burst, re-pack the sterilization material and re-sterilize it.

If you remove the sterilized equipment from the device directly after the end of the program, it is possible that the instruments can be partially damp. According to the Arbeitskreis für Instrumentenaufbereitung (AKI; red brochure 10. Edition; S.57): "In practice, residual moisture in the form of a few drops of water capable of evaporating within 15 minutes is tolerated, but actual pools of water are not acceptable."

Comply with the following specifications when removing the sterilized equipment:

- ▶ Never use force to open the door. This could damage the device and / or result in the emission of hot steam.
- ▶ Hold the mount level when removing it from the steam sterilizer. Otherwise, the load could slide off.
- ▶ When removing the load from the steam sterilizer separately, ensure that the mount does not slide out unintended.
- ▶ Use a tray lifter to remove the tray.
- ▶ Never touch the sterilized equipment, the device interior or the inside of the the door with unprotected hands. The components are hot.
- ▶ Check the packaging on the sterilized equipment for damage when removing it from the device. Should the packaging be damaged, re-pack the sterilization material and re-sterilize it.

## Storing sterile instruments

The maximum storage time is dependent on the packaging and the storage conditions. For standard-conform packaged sterilized equipment – (if protected from dust) it can amount to up to six months. Comply with the provisions of DIN 58953, part 8 and the criteria specified below for the storage of sterilized equipment:

- ▶ Comply with the maximum storage duration in accordance with the packaging type.
- ▶ Do not store the sterilized equipment in the decontamination room.
- ▶ Store the sterilized equipment in a dust-protected environment e.g. in a closed instrument cabinet.
- ▶ Store the sterilized equipment in a moisture-protected environment (e.g. alcohol, disinfectant)
- ▶ Store the sterilized equipment in an environment protected against excess temperature variations.



## 8 Logging

---

### Batch documentation

The batch documentation acts as proof of the successful conclusion of the sterilization process and represents an obligatory part of quality control. The data, such as type of program as well as batch and process parameters of the completed programs, are stored in an internal log memory of the device.

To obtain the batch documentation, you can read out the internal log memory and transfer its data to various output media. This can be performed immediately at the end of every program or at a later point, such as at the end of the day.

#### **Capacity of the internal log memory**

The steam sterilizer is equipped with an internal log memory. This saves all the data regarding the sterilization program automatically. The capacity of the internal log memory is sufficient for c. 100 logs. If the internal log memory becomes almost full and at least one log has not been outputted via an activated output medium, the following warning "Internal log memory is almost full" will appear on the display. If this warning appears, working in the **Settings** menu → **Logging** provide the pre-determined output media and output the logs affected (→ **Log output** menu).

Shortly afterwards, the following message is displayed: Internal log memory full. You now have the last chance to archive logs which have not been outputted (confirm query with YES) before the data in the steam sterilizer log memory (up to the last 40 logs) is automatically deleted.

### Output media

You are able to output and archive the logs of the completed programs on the following output media:

- MELAflash CF card
- A computer (via the practice network)
- Label print-out with the MELAprint 60 label printer
- MELAprint 42 log printer with network adapter

Any combination of the output media is possible. Log output on multiply activated media is performed successively. In its delivery state, the MELAflash CF card is activated as the output medium for text and graphic logs from the steam sterilizer. Automatic logging (= Immediate output) is thus activated.

Detailed information regarding the activation and setting of log output is to be found in the chapter [settings, logging](#) [▶ page 42].

### Using the CF card as an output medium

---



#### **NOTICE**

**Premature removal of the CF card from the card slot or its inappropriate handling can result in data loss, damage to the CF card, the device and/or its software.**

- Never push the CF card in the slot with force.
  - Never remove the CF card from the slot whilst it is being written or read. The square in the upper right-hand corner of the display lights up during reading and writing access.
- 

The card slot for the CF card is located on the right-hand side of the display housing.

Proceed as follows in order to insert the CF card in the slot.

✓ *The CF card is set as the output medium in the **Settings** → **Logging** menu.*

1. Insert the CF card in the card slot fully with the raised finger edge pointing rightwards and to the rear. If the CF card is inserted correctly, a blue square will illuminate in the right upper corner of the display.

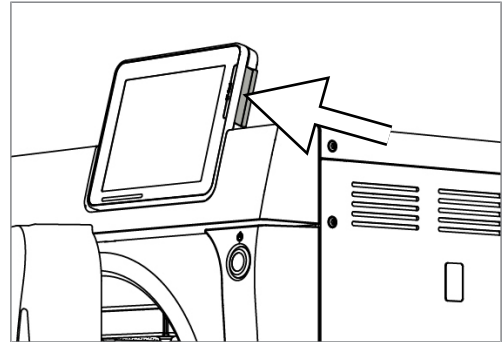

2. Check whether the CF card has been selected as the output medium.

## Using the computer as an output medium

You can connect the steam sterilizer directly to a computer or integrate it in an existing (practice) network via FTP or TCP. The computer must be fitted with a RJ45 socket (LAN).

Further information pertaining to the requirements and setting of the computer as an output medium is available in the chapter [Settings, logging](#) [▶ page 42].

## Reading out a text log on the computer

All text logs can be opened and printed out using a text editor, a word processing program or a spreadsheet program. Graphic logs can only be displayed with the MELAtrace/MELAview documentation software.

Each text log (e.g. PRO, .STR, .STB etc.) must be linked with the text editor to enable the computer to open them automatically with a text editor. The meanings of the endings are outlined in the section [Subsequent log output](#) [▶ page 36]. The following examples show how you can link the Windows 7 editor with a specific text log.

1. Working in Windows Explorer, double click on the log file.
2. If the file ending is unfamiliar, Windows 7 will display the following message:

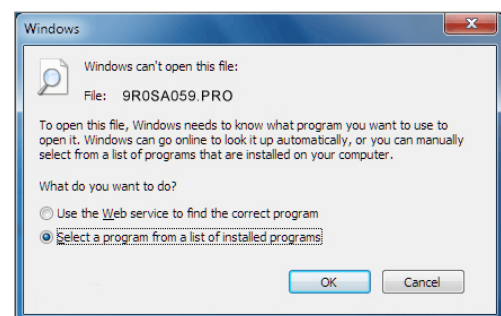

3. Select "Select a program from a list of installed programs" and confirm with "OK".

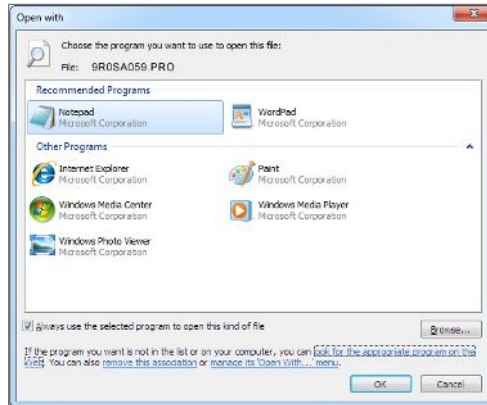

4. You can then open files with this ending via a double-click in Windows Editor.

### Using the label printer as an output medium

The use of a label printer facilitates batch traceability. Using the sterilization date, the storage duration, batch number, user ID of the person approving the application for use, the steam sterilizer used and the file name it is possible to assign the sterilized instruments to the patient and sterilization batch. Faultless packages containing sterilized equipment are marked with labels after sterilization. As such, the preconditions for correct "Approval" by the person conferred with the task of decontamination are given. All information regarding the correct sterilization procedure can be attributed to the instruments used in patient records.

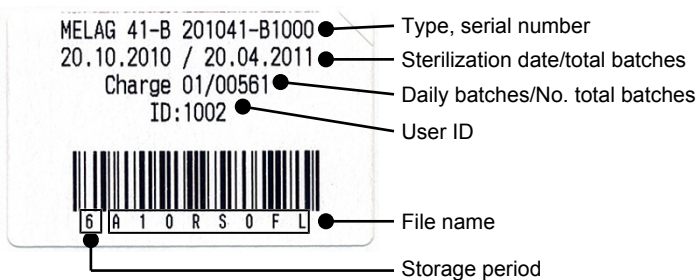

#### NOTICE

To facilitate easy assignation of a package marked with a label to a specific batch, the sterilization log file name must not be changed.

### Outputting text logs automatically after program end (immediate output)

If you want to output the associated text and graphic logs on an output medium immediately after the end of a program, use the "Immediate output" option. In its delivery state, the immediate output of the text and graphic logs via the CF card after program end is activated.

If the output medium selected for this purpose has not been connected, the logs are saved in the internal memory and a warning is issued. The steam sterilizer provides the option of outputting this log at the next possible opportunity. Graphic logs cannot be saved in the internal log memory; they are lost. Further information pertaining to the output of graphic logs is available in the section [Outputting graphic logs \(optional\)](#) [▶ page 42].

The following points must be fulfilled for immediate output:

- ▶ The date and time have been set correctly.
- ▶ The output medium must have been selected and connected.
- ▶ Immediate output must be activated in the **Settings** menu → **Logging**.

Information regarding the setting of immediate output and the desired output medium is provided in the chapter [Settings, logging](#) [▶ page 42].

## Subsequent log output

The **Log output** menu provides the option of outputting text logs subsequently and independently of the point of the program end. You can set the output media yourself. The output medium is selected as standard, which are also selected under **Settings** → **Logging**, as far as automatic immediate output is activated.

The Log output menu offers various opportunities for log output. All program logs present in the memory are displayed in the Logging list. You can sort the list according to date, time, program and outcome by pressing on the column headings. Here is an overview of all possible output media.

Designation	File ending	Explanation
Last log	.PRO	The log of the last successful completed program is outputted.
Logs of the day	.PRO	The log of the last successful program of the current day is outputted.
Logs of the week	.PRO	Logs of all successfully completed programs of the week - Monday to Sunday - are outputted.
Logs of the month	.PRO	Logs of all successfully completed program performed in the current month are outputted.
All logs	.PRO	The logs of all the successfully completed programs are outputted.
Last fault log	.STR	The last malfunction log are outputted.
Fault logs of the day	.STR	The malfunction logs of the current day are outputted.
etc.	...	
Legend log file	.LEG	Contains an explanation of all abbreviations contained in the log.
Status log	.STA	A summary of all important settings and system states (counter, measured values etc.)
Fault in standby	.STR	This log type is generated following the malfunctions registered during a time at which no program was active.
System log	.LOG	A sort of log book listing all malfunctions and changes to the system in order of their incidence.
Delete all logs		Deletes all logs stored in the internal log memory. Caution: All logs will be deleted which were not previously outputted to another output medium.

### Outputting a log from the log list

Proceed as follows to output a specific log from the internal memory:

1. Navigate to the **Log output** menu and select **Logging list**.

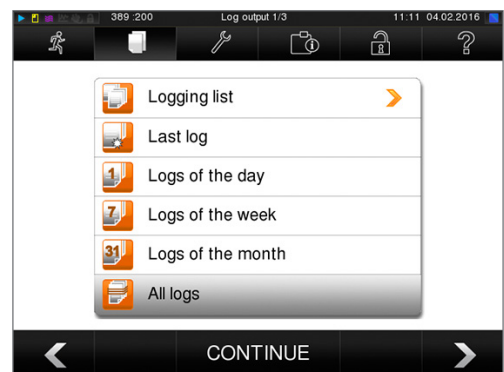

2. A list with all text logs is displayed which have been saved in the internal memory. To ease the search, you can filter the log sort sequence by date, program or event by selecting the top line.

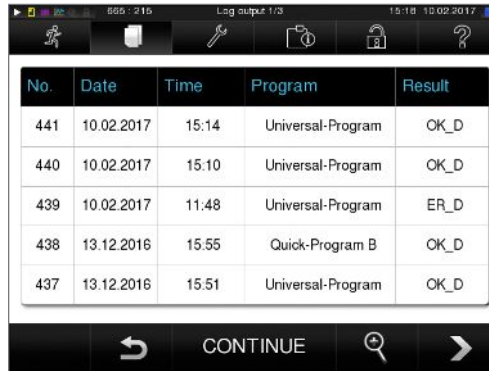

3. Select a log and press CONTINUE.
4. Select an output medium and press OUTPUT.



**Outputting the daily/weekly logs etc.**

Proceed as follows e.g. to output all the logs of a week:

1. Navigate to Log output and select Logs of the week.

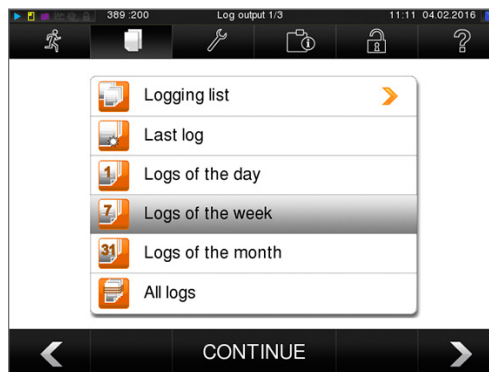

2. Press CONTINUE.
3. Select an output medium and press OUTPUT.

Proceed in a similar fashion to output all logs, all the logs of that month etc.

## Finding a log



### PLEASE NOTICE

If possible, do not rename the directories, otherwise logs will be stored in both the renamed directory as well as the new device directory generated automatically by the steam sterilizer.

### Storage location for logs

When transferring the logs to a CF card, they will be stored in a separate folder in the main directory. Direct transfer of the log to a computer via the network and using the MELAG FTP server allows you to work directly in the FTP server to determine directly where on your computer the device directory with log files is to be saved. With output via TCP and e.g. MELAtrace, you can work directly in the program to determine the folder in which they are to be saved.

### Log directory

All memory media (CF card or computer) contain a folder with the encoded serial number of the steam sterilizer concerned. The folder name consists of five characters identical with the first five characters of every log, e.g. E00T7. This folder contains sub-folders with the month of log generation e.g. 01\_2016 for January 2016. This contains all logs generated by the steam sterilizer this month. The device directory is entered in the main directory on the CF card.

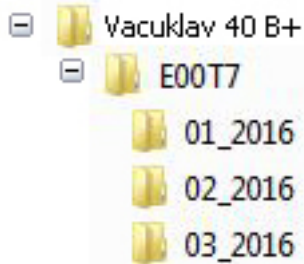

The steam sterilizer checks the memory medium after every type of log output (immediate output after a completed cycle or the transfer of multiple logs simultaneously). Should a directory not exist, it automatically creates a directory for the device and the month. If the logs are subject to multiple outputting on the identical memory medium, the device directory will create a "Duplicate" directory.

Further information pertaining to the meaning of the file endings on the logs is available in section [Subsequent log output](#) [▶ page 36].

<pre> ----- !0 01100ED0E001 !1 E00T717U.PRO ----- 10 MELAG Vacuklav 41 B+ ----- 15 Program:      Universal-Program 20 Program type: 134 °C wrapped 25 Date:         09.03.2017 30 Daily batches: 14 Total: 01578 35 User:         Deactivated 36 Indicators changed: deactivated 37 Batch approved: deactivated ===== 40 Universal-Program successfully   completed 42 = = ===== 45 Temperature: 135.3 +0.25/-0.18 °C 50 Pressure:     2.17 +0.02/-0.01 bar 55 Plateau time: 05 min 30 s 60 Conductivity: 8 µS/cm (359:11.1) 65 Start time:   20:22:01 70 End time:     20:43:19 (21:18 min) ===== 80 SN:201441-B1051 ===== 81 MR   V3.218 09.03.2017 82 Para V3.226 17.02.2017 83 BO   V3.323 09.03.2017 ----- Step  Time t[m:s]  P[mbar]  T[°C] SP-S  0:00   0:00   1002   96.3 SK11  0:13   0:13   1680   95.7 SK12  0:37   0:24   1285   104.8 SK11  0:46   0:09   1665   106.8 . . SK22  2:38   0:20   1284   116.6 SF12  3:12   0:34   499    112.7 SF13  3:42   0:30   1667   113.3 . SF43  8:25   0:24   1749   113.6 SH01  9:10   0:45   2780   130.5 SH02  9:31   0:21   2847   131.7 SS01  9:53   0:22   3065   134.0 SS02  15:23  5:30   3169   135.3 SA00  15:53  0:30   1292   112.1 SI02  17:33  1:40    79    57.9 . SB10  21:14  0:12    804   91.3 SB20  21:18  0:04    919   92.3 SP-E  21:18  0:00    925   92.3 &gt;&gt; Never change the code in the following line &lt;&lt; 010041D8BE14B1319E55772A0DF975054F7EBF32 EE1372767ED3B3801EB10F3FB01A3212D41D7144 1C3B8B6474777962766F018680B68C56C219074F D6E7814D506F0A2F3077782541CC2CD05C425DA1 9A5EF5192C68174C868556542F7B8B05E97C6E46 16CDCFFA811E126FD67363FB74128A5F83AE6F37 F45A9E240C88615F1618D340060C1027205C83C2 &gt;&gt;Authentication of batch log&lt;&lt; ----- 0.00  0.0  0.0  0.0  ---.-  0.0 -edk---etm---etd---etp---etv---ett-END- </pre>	<pre> !0 Ident number !1 File name ----- 10 Steam sterilizer type ----- 15 Program name 20 Program sterilization parameters 25 Date 30 Daily and total batch number 35 User ID 36 Batch indication 37 Batch approval ===== 40 Control notification 42 Warning or malfunction message with program abort ===== 45 Sterilization temperature with max. deviations 50 Sterilization pressure with max. deviations 55 Sterilization time 60 Conductivity of the feed water 65 Time at program start 70 Time at program end ===== 80 Device serial number ===== 81 Current version of the device firmware 82 Current version of the device parameters 83 Current version of the user interface ----- Step – Program step  Time – Time (min:sec) which has elapsed since the program start  t [m:s] – Duration (minutes:seconds) which a program step requires  P [mbar] – Chamber pressure  T [°C] – Chamber temperature  Key for the program steps: SK – Conditioning SF – Fractionation SH – Holding SS – Sterilization SA – Pressure release ST – Drying SI – Intelligent drying SB – Ventilation SP-E – End  ----- Proof of authenticity (electronic signature)☐Should never be altered; decoding the code (by MELAG) indicates whether the data was generated on a MELAG steam sterilizer and has been changed.  ----- Sensor measurement values are displayed here in the case of a malfunction. The values are helpful for a technician. </pre>
--	---

Fig. 4: Example log of a successfully completed program

## 9 Functional checks



### PLEASE NOTICE

Please comply with the recommendations issued by the Robert-Koch-Institute (RKI) and DIN 58946-7.

#### Manual functional checks

You can follow the program run on the display via the values displayed there. You can also use the logs recorded for every program to determine the success of a program. The test programs enable you to perform an additional function check at any time.

### Vacuum test

The steam sterilizer can be checked for leakages in the steam system using the Vacuum test. This determines the leakage rate at the same time.

Perform a vacuum test in the following circumstances:

- Once a week in routine operation
- During commissioning
- Following longer operating pauses
- Following a malfunction (e.g. in the vacuum system)

Perform the Vacuum test with the steam sterilizer in a cold and dry state as follows:

1. Switch on the steam sterilizer at the power switch.
2. Working in the **Programs & Tests** menu, select vacuum test and press START.

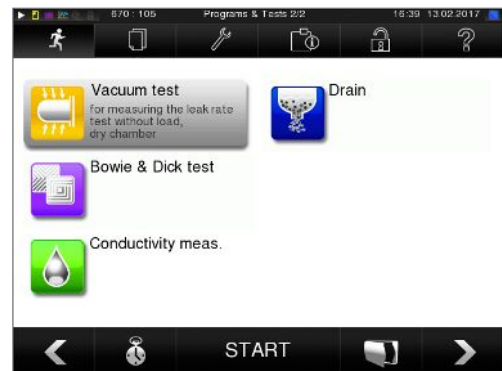



## Bowie & Dick test

The Bowie & Dick test serves as the proof of steam penetration of porous materials such as e.g. textiles. You can perform a routine function check for proof of steam penetration. Use the Bowie & Dick test program to this end. Specialist stockists provide various test systems for the Bowie & Dick test. Perform the test according to the test system manufacturer information.

1. Switch on the steam sterilizer at the power switch.
2. Working in the **Programs & Tests** menu, select Bowie & Dick test and press START.



### ***Evaluation of the indicator documents following the colour change***

Depending on the manufacturer batch, treatment indicator strips often exhibit differing intensities in the colour change resulting from different lengths of storage or other influences. Of crucial importance for evaluating the Bowie & Dick test is not the strength of contrast in the colour change on the test sheet, but its even nature. If the treatment strips / treatment indicator sheet indicates an equal distribution of colour change, the air removal of the sterilization chamber is without fault. If the treatment indicator strips or the treatment indicator sheets are uncoloured or exhibit less colour in the centre of the star in comparison to the end, air removal was insufficient. In such a case, please consult the stockist customer services of the customer services / authorized stockist.

# 10 Settings

## Logging

All settings pertaining to the output of text and graphic logs i.e. output medium, log format, immediate output etc. are performed in the Settings menu → **Logging**.

To this end, you are led through a settings wizard.

### Immediate log output

In its delivery state, the immediate output of the text and graphic logs via the CF card is activated immediately after the program end.

#### *Deactivate immediate output*

If log output is not to be performed immediately following the end of a program, but saved in the internal memory, (e.g. to be collected and outputted together within a single week), you can deactivate the immediate output option. Proceed in the following fashion:

---

✓ *Navigate to **Settings** → **Logging**.*

---

1. Remove the checkmark in front of the **Immediate output** option.

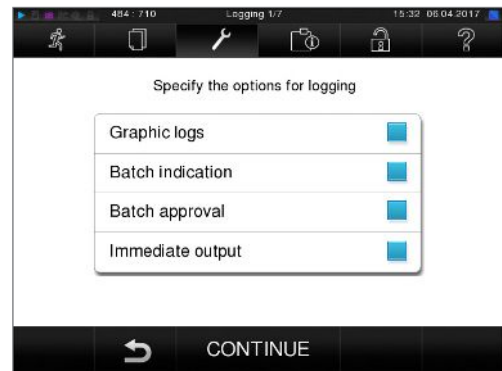

2. Press repeatedly on CONTINUE until you come to the summary window.
3. Press SAVE to save the setting.

### Outputting graphic logs (optional)



#### **PLEASE NOTICE**

**Graphic logs cannot be saved in the internal log memory. A subsequent output of graphic logs is thus not possible.**

---

If you wish to output a graphic log (optional) in addition to a text log, proceed as follows:

- ✓ *Navigate to **Settings** → **Logging**.*
- ✓ *Immediate output is activated.*

1. Set a checkmark next to the Graphic logs option and check whether the checkmark is also set next to the Immediate output option.



2. Press CONTINUE and select the CF card and/or computer as an output medium.

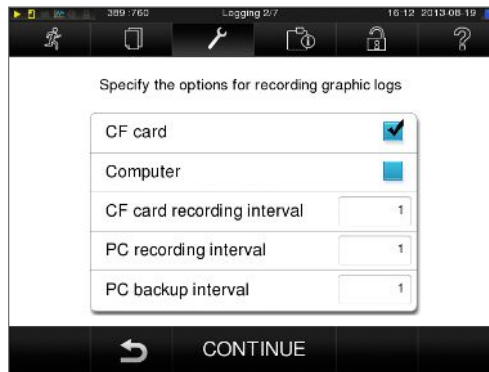

- 3. If necessary, change the intervals and press CONTINUE.
- 4. Working in this window, check whether at least one of the two output media have been selected for text logs.
- 5. Check whether the activated output medium is connected (computer) or has been inserted (MELAflash CF card).
- 6. Press repeatedly on CONTINUE until you come to the summary window.
- 7. Press SAVE to save the setting.

Explanation of the possible settings for graphic recording:

Interval	Explanation
<b>CF card (CFC) recording interval</b>	in sec. – indicates the time intervals in which the program curve is recorded on the CF card. The smaller the time interval, the more exact the curve. In the example, the time interval is set at 1 second.
<b>PC recording interval</b>	in sec. – indicates the time intervals in which the program curve is recorded, if the computer is selected as output medium. The smaller the time interval, the more exact the curve. In the example, the time interval is set at 1 second.
<b>PC backup interval</b>	in sec. – indicates the time interval in which the graphic data from the steam sterilizer is saved on the computer. In example 1, the backup interval is set to 1 seconds.

## Using the computer as an output medium

Log transmission can be performed via an FTP server / service or TCP. The following section shows how to set the desired connection:

- ✓ *Navigate to the **Settings** → **Logging** menu.*
- ✓ *The steam sterilizer is connected to a computer via a network cable (RJ45).*
- ✓ *Depending on the output type, an FTP server / service or a suitable program e.g. MELAtrace / MELAview is installed.*

1. Press on CONTINUE until you reach the window for selecting the output medium.

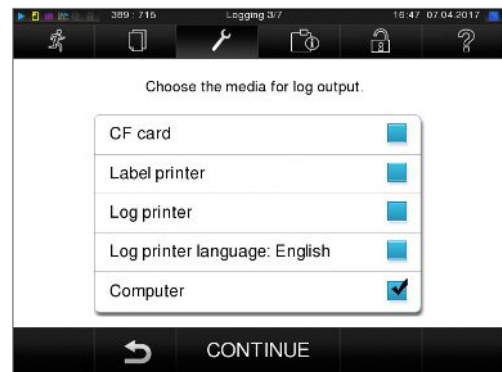

2. Select the computer as an output medium and press CONTINUE.
  - ↳ The selection window opens and asks whether the connection to the computer should be effected via FTP or TCP.

## IP addresses



### PLEASE NOTICE

Those setting up the (practice) network will require in-depth understanding of the network technology.

**Errors in the handling of IP addresses can result in malfunctions and data loss in your user network.**

- Setting of IP addresses should only be performed by the system administrator of the (practice) network.

The device is equipped as standard with IP addresses which all belong to a common network with the subnet mask stated in the following depiction.

Device	IP address	Remarks
Steam sterilizer	192.168.40.40	Preset works side
Computer	192.168.40.140	Preset works side
Log printer MELAprint 42	192.168.40.240	Preset works side
Label printer MELAprint 60	192.168.40.160	Preset works side
Gateway	192.168.40.244	Not relevant within a network
Subnet mask	255.255.255.0	Possibly to be adopted by customer network

If a device is to be integrated in a pre-existing (practice) network, observe and comply with the following:

- ✓ *The IP addresses listed in the table have not yet been assigned in the (practice) network.*
- ✓ *The device cannot be automatically administered in a dynamic (practice) network (i.e. a DHCP network).*

1. Select the **Settings** menu → **Logging**. The setting wizard opens.

2. Working in the logging wizard, navigate to the window in which the IP addresses of the individual devices are listed.

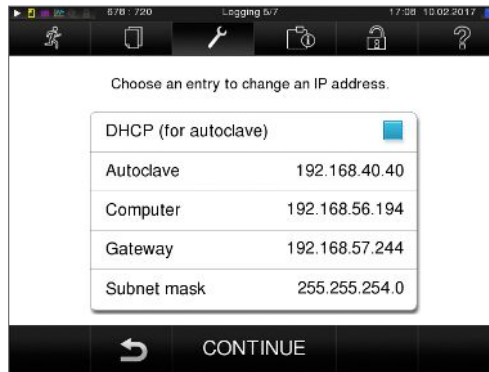

3. Select e.g. the steam sterilizer. The settings window opens.



4. Select the number block which you wish to change directly.

5. Use the C button to delete the numbers. Enter a new number block and confirm with SAVE.

6. Proceed in a similar fashion with the other devices which are to be integrated in the network.

## Log format

Different data is issued depending on the nature of the logging format.

- ▶ The logging format is determined under **Settings** → **Logging**.

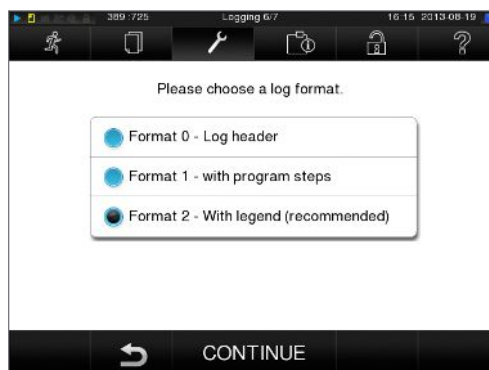

You can choose between the following formats.

Format	Description
Format 0	Short form - only the log header is outputted.
Format 1	The log header and the program steps are outputted.
Format 2	Standard format - in addition to the log header and the program steps, a key is displayed explaining the individual program steps. In logs outputted via the log printer MELAprint 42, the corresponding legend row is always located under the row to which it refers.

In logs outputted via the log printer MELAprint 42, the corresponding legend row is always located under the row to which it refers.

## User administration

An individual ID and user PIN can be issued to every user to facilitate reliable traceability via the approval process after the end of a sterilization program. The user is able to authenticate himself before providing the batch with approval. You can determine the necessity of user authentication via a PIN in the User administration menu by setting a checkmark against Batch approval with PIN. Activation of this option documents the user ID and the outcome of the approval procedure in the log header.

### Adding a user

1. Select **Settings** → **User administration**.



2. Entry of the Admin PIN is necessary to reach the User administration menu and undertake settings. Enter the Admin PIN (standard 1000) and confirm with LOGIN. The display switches to the User administration window.

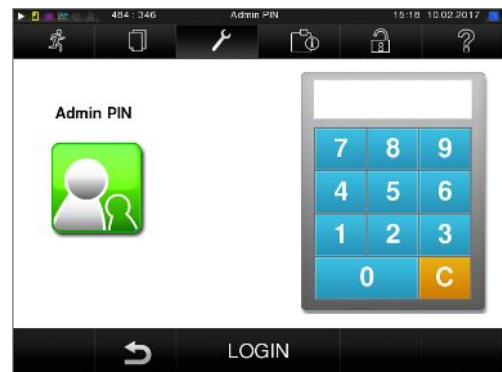

3. Press "Continue to user list" to display the user list.

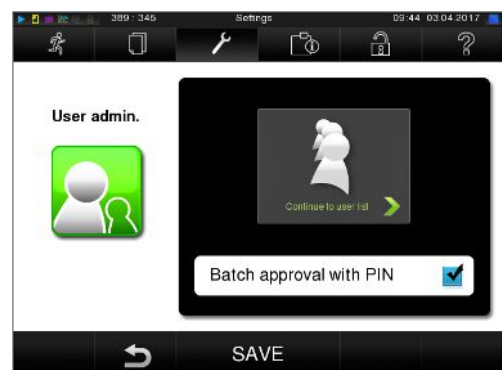

- Select a free ID and select EDIT in order to create a new user. The first ID is reserved for the Admin PIN.



- Enter a 4-digit PIN in the right-hand key pad for the selected User ID.

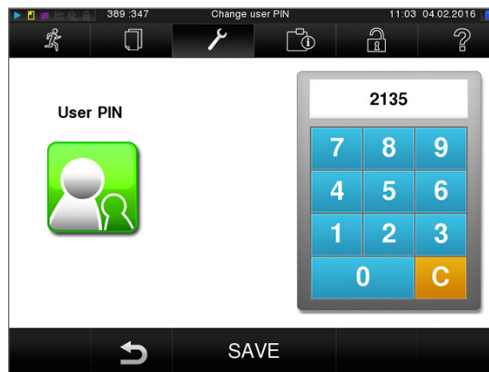

- Accept all the settings with SAVE and then leave the menu.
- Pressing the  symbol enables you to leave the menu.

### Deleting a user

- Select the **User administration** option as described above and open the user list.



- Select the User ID which you wish to delete.
- Press the  symbol to delete this menu.
  - A warning is issued.
- Confirming the warning with YES will set the PIN number of this ID to "0".
  - A new PIN can be issued for this user ID at any time.

## Changing the Admin PIN



### PLEASE NOTICE

If you forget the Admin PIN, consult your stockist/MELAG customer services provider.

The Admin PIN (standard: 1000) can be edited like every other User PIN and should be changed after delivery.

## Formatting the CF card



### NOTICE

All data saved on the CF card is deleted during formatting.

- Check whether important data is stored on the CF card.
- Save any logs or other data on the computer or another memory medium.

1. Insert the CF card in the steam sterilizer card slot correctly (tangible raised bar on the edge pointing back right). Do not use force.
2. Select the **Settings** → **Format CF card**. The display switches to the corresponding window.



3. To start formatting, press the OK button. Confirm the security query with YES. You can remove the CF card as soon as formatting has been completed.

## Additional drying

Selecting additional drying extends the drying time of conventional drying by 50 %. Activating intelligent drying restricts the criteria for ending the drying phase.

1. Select **Settings** → **Additional drying**. The display switches to the settings window.

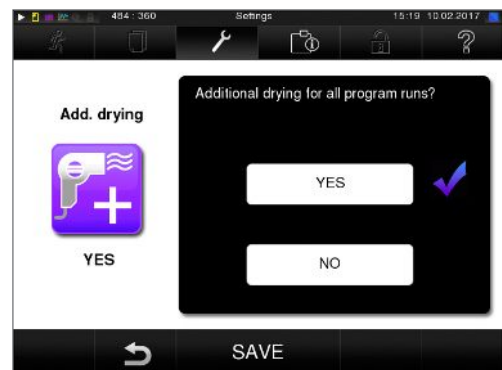

2. Press YES or NO, to chose whether additional drying should be performed during the next program run.



3. Confirm with **SAVE**.

## Intelligent drying

In contrast to a conventional time-controlled drying procedure, with which the duration of the drying phase is determined by the program, the duration of the intelligent drying is automatically calculated using the residual moisture in the sterilization chamber. A number of factors play a role in this process including e.g. the nature of the load, wrapped or unwrapped, the load quantity, the distribution of the load in the sterilization chamber etc. Comply with the specifications in section [Loading the steam sterilizer](#) [▶ page 22].

Intelligent drying is activated in the delivery state. Should you wish to deactivate intelligent drying, proceed as follows:

1. Select the **Settings** → **Device settings** → **Intelligent drying**. The display switches to the corresponding window.
2. If you wish to deactivate intelligent drying, select **NO**.



3. Confirm with **SAVE**.

## Water supply

Select the corresponding setting in the display, depending on whether the feed watersupply is effected using the internal storage tank or a water treatment unit:

1. Select the **Settings** menu.
2. Navigate to **Water supply** → **Device settings**.  
 ↳ The display switches to Water supply window.
3. Select **EXTERNAL**, if the supply is to be performed via the internal storage tank or **INTERNAL**, if you have connected a water treatment unit.



4. Confirm with **SAVE**.

## Date & time

Correct batch documentation requires the correct date and time setting on the steam sterilizer. Ensure that you take into account the clock change in autumn and summer, as this is not adjusted automatically. Once the time has been set on the steam sterilizer, it is very accurate. Set the date and time as follows:

1. Select **Settings** → **Date & time**. The display switches to the settings window.

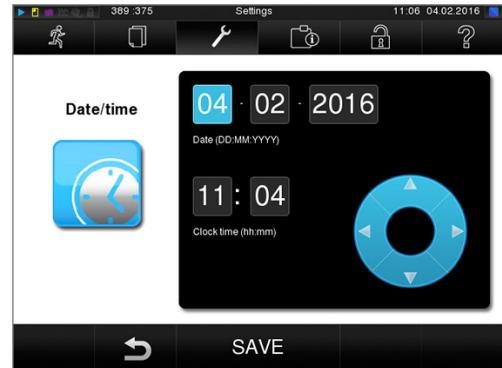

2. Select the parameters which you wish to change (day, month, year / hour, minute second). The marked parameter is depicted light blue, here e.g. the hour.

3. Change the respective value via the

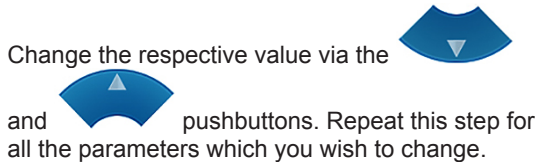

and pushbuttons. Repeat this step for all the parameters which you wish to change.

4. Confirm the changes with **SAVE**.

→ The display will be restarted after saving and then changes automatically to the Programs & Tests menu.

## Brightness

1. Select **Settings** → **Brightness**. The display switches to the settings window.





2. Press the pushbuttons **-** or **+** to adjust the brightness and contrast on the display.
3. Accept all the settings with **SAVE** and then leave the menu.

## Volume

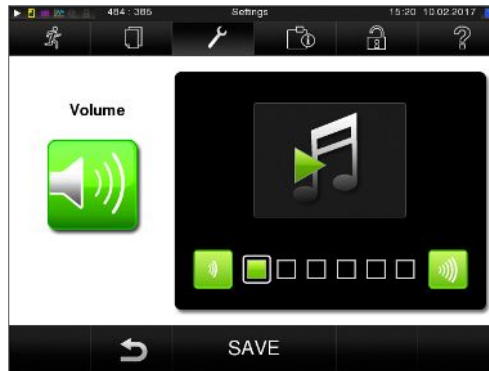
1. Select **Settings** → **Volume**. The display switches to the settings window.



2. Press the  or  pushbutton to adjust the volume.
3. Accept all the settings with SAVE and then leave the menu.

## Key tone

1. Select **Settings** → **Key tone**. The display switches to the settings window.

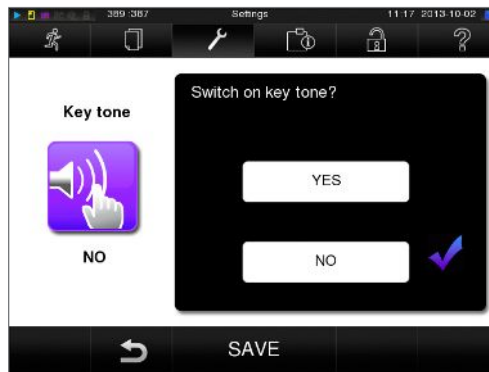

2. Press YES or NO to determine whether a tone should be emitted every time a pushbutton is pressed. This can be deactivated at any time.
3. Accept all the settings with SAVE and then leave the menu.

## Screensaver

A screensaver can be activated to protect the display in standby operation. This displays a continuous slide show of any pictures.

### Select images for the slide show

1. Select **Settings** → **Screensaver** . The display switches to the settings window.



2. Tap on a picture to select it. The white frame around the picture indicates which picture is currently selected.
3. Repeated tapping on the picture selects/deselects it for the slide show.
  - The checkmark on the lower right-hand corner  indicates whether the picture has been selected for the slide show.
4. Press CONTINUE to make further settings.

### Set the display duration of the images and the waiting time of the slide show.

Proceed as follows to alter one of the named options:

1. Select the parameter directly that you wish to change. The marked parameters are displayed light blue.

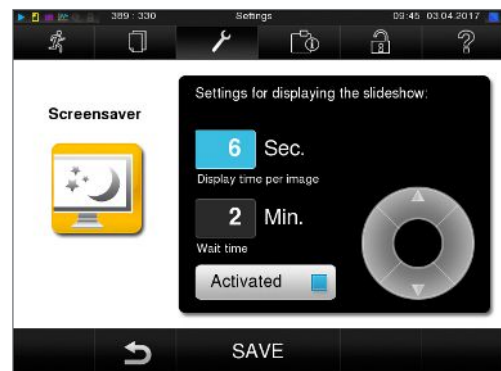



2. Change the respective parameter value via the  and  pushbuttons.
3. Confirm the settings with SAVE. The display switches automatically to the **settings** menu.

Table 1: Explanation of the slide show options

<b>Display duration per image</b>	Indicates the time in seconds between the display of two separate pictures.
<b>Waiting time</b>	Indicates how long the display remains in normal mode before the slide show starts.
<b>Activated</b>	Setting/unsetting the checkmark activates/deactivates the screensaver.

## Log printer MELAprint 42

If you wish to output the sterilization log via the log printer MELAprint 42, you need to set this on the steam sterilizer once. The operating manual of the log printer indicates how to set it up.

## Label printer MELAprint 60

If you wish to output the sterilization logs via the label printer MELAprint 60, you need to set this on the steam sterilizer once. The operating manual of the label printer indicates how to set it up.

## Sensitivity

1. Select **Settings** → **Touchscreen sensitivity**. The display switches to the settings window.

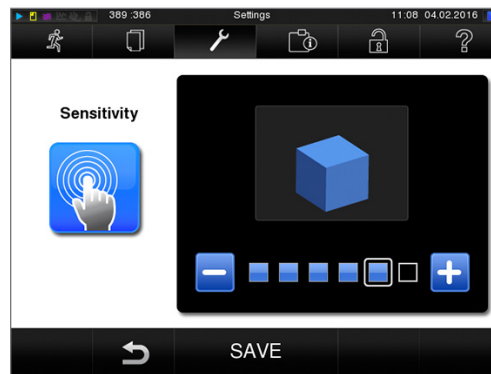

2. You can determine the pressure required to activate a pushbutton. using the **-** and **+** pushbuttons.
3. Accept all the settings with **SAVE** and then leave the menu.

## Energy-saving mode

If the steam sterilizer is not be switched off during longer operating pauses, it can be operated in energy-saving mode. This reduces the time which the steam sterilizer requires in order to pre-heat the double-jacket steam generator to the necessary start temperature after deactivation. Two waiting times can be set in energy-saving mode:

**Waiting time 1 (W1):** After a re-set waiting time of 15 minutes, the temperature of the double-jacket steam generator will sink to 103°C. The program run time becomes c. 2 minutes longer upon the next start.



**Waiting time (W2):** After a pre-set waiting time of 60 minutes, the double-jacket steam generator is no longer heated. Accordingly, the length of the program run time increases by about 5 minutes upon the next start, depending on the length of the operating pause, as the double jacket steam generator must first be pre-heated to the necessary start temperature.

Setup of the energy-saving mode is described here:

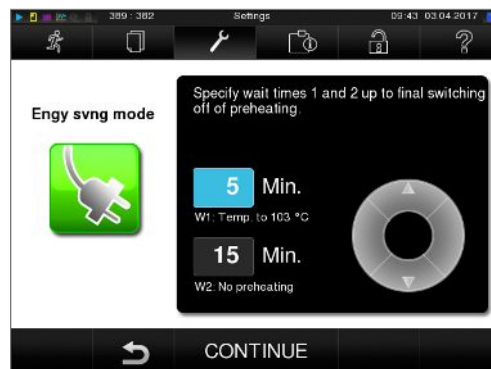
1. Select **Settings** → **Energy saving mode**. The display switches to the settings window.



2. Select Waiting time 1 directly by touching the time. The area is displayed light blue.

3. Change the minutes using the  and  pushbuttons.

4. Repeat the step for waiting time 2.
5. Press CONTINUE.

## Switching off the display

Optionally, you can choose whether the display is to be switched off when the steam sterilizer is in energy-saving mode: The double jacket will not be heated until the next program start. This corresponds to waiting time 2.

1. Set the checkmark next to "Activated" and set the number of seconds after which the display is to be deactivated.



2. Confirm the settings with SAVE. The display switches automatically to the Settings menu.
3. You can switch the display back on by touching the screen.

# 11 Maintenance

## Servicing intervals

Interval	Measure	Device components
Weekly	Check for soiling, deposits or damage	Chamber inc. door seal and chamber sealing face, mount for the load
With every filling of the storage tank	Check the storage tank for soiling and clean it if necessary before filling	Internal storage tank
Every 2 weeks	Clean the left-hand chamber of the storage tank (waste water)	Internal storage tank
After 2 months	Oil the door spindle	Door mechanism
After 2 years or 2000 cycles	Maintenance	By the authorized customer services working in accordance with the maintenance instructions.
As required	Cleaning the surfaces	Housing parts

## Cleaning



### NOTICE

**Inappropriately performed cleaning can lead to the scratching of and damage to surfaces and the development of leaks in sealing surfaces.**

**This also favours the development of soiling deposits and corrosion in the sterilization chamber.**

- Comply with all information regarding cleaning of the part affected.

### Door seal, chamber, chamber sealing face, mount, trays

Check the chamber, door seal, chamber sealing face and the load mount **once a week** for soiling, deposits or damage.

If you find any impurities, remove the trays or cassettes from the chamber from the front. Clean the soiled components.

When cleaning the chamber, load mount and chamber seal face, please comply with the following:

- ▶ Switch off the steam sterilizer before cleaning and remove the power plug from the socket.
- ▶ Ensure that the chamber is not hot.
- ▶ Use a soft, non-fuzzing cloth.
- ▶ First soak the cloth with cleaning alcohol or spirit and attempt to remove the impurities with this method.
- ▶ Use a chlorine- and vinegar-free cleaning fluid.
- ▶ Only if the chamber, mount or chamber seal face has persistent soiling should you use a mild, non-scouring, stainless steel cleaning agent, with a pH value between 5 and 8.
- ▶ Use a neutral liquid cleaning agent to clean the door seal.
- ▶ You should not allow cleaning fluid to enter the piping coming from the chamber of the steam sterilizer.
- ▶ Do not use any hard objects such as a metal saucepan cleaner or a steel brush.

### Housing parts

Where necessary, clean the housing parts with a neutral fluid cleaner or spirit.

## Internal storage tank

Should you use the internal storage tank for the feed water supply, perform regular checks and cleaning as follows:

Interval	
Upon every refill	Check the storage tank for soiling. If necessary, clean the storage tank with fresh feed water before filling.
Every 2 weeks	Clean the left-hand chamber of the storage tank (waste water).

### Empty the chamber of the internal storage tank

1. Open the service hatch in the lower area of the steam sterilizer.

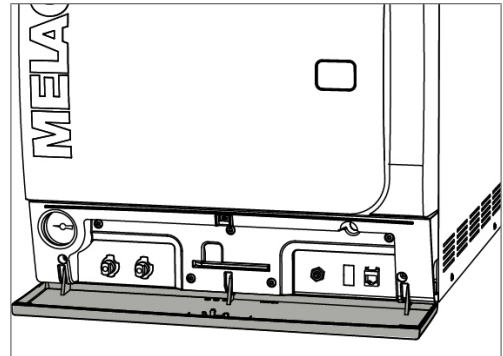

2. Place a min. 5 L bucket in front of the steam sterilizer.
3. Connect the drain hose onto one of the drain fittings on the waste water side (pos. a) or the feed water side (pos. b) until it snaps into place. The knob must be vertical.

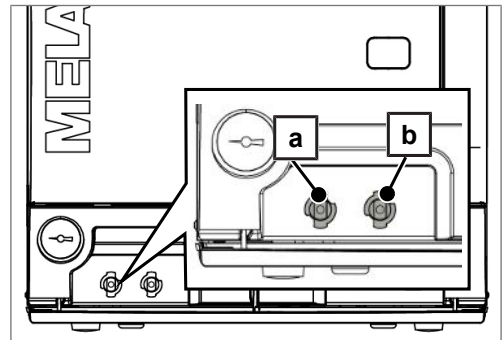

4. Open the water drain tap by turning the knob 1/4 in a clockwise direction.

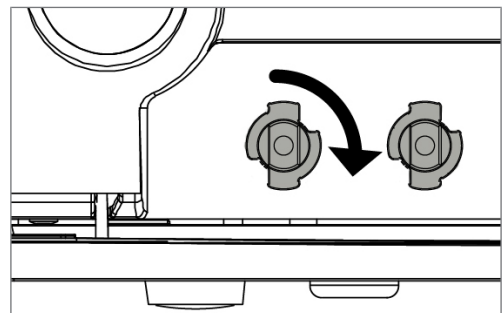

5. To remove the drain hose, turn the hose connection into the vertical position.



### **Cleaning the feed and waste water side**

You can remove the cover of the storage tank completely to clean the chambers of the internal storage tank.

1. Remove the fore tank lid.
2. Grasp the cover on the filling opening and then lift the cover upwards a little.

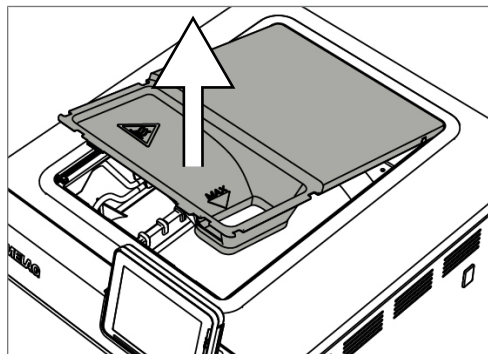

3. Remove the cover from the rubber seal completely.

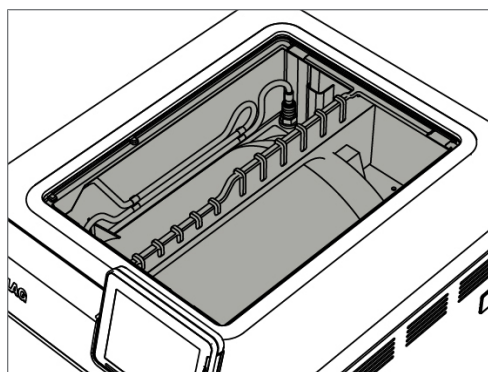

## **Avoiding staining**

Only after cleaning instruments properly prior to sterilization is it possible to avoid residue from the load or the instrument decontamination from being released during sterilization. Loosened dirt residue can clog the filter, nozzles and valves of the steam sterilizer and deposit themselves on the instruments and chamber as deposits and stains.

All steam-conducting parts of the steam sterilizer consist of non-rusting material. This rules out the possibility of stain or rust development being caused by the steam sterilizer. The development of rust is always extraneous rust.

Incorrect instrument decontamination can result in the accretion of rust even on stainless steel instruments of leading manufacturers. Often, an instrument which drops rust can suffice to cause the development of rust on another instrument or in the steam sterilizer. Remove foreign rust from the instruments using a chlorine-free stainless steel cleaning agent (see section [Cleaning](#) [▶ page 55]) or send the damaged instruments to the manufacturer.

The extent of stain accretion on the instruments is also dependant on the feed water used for steam generation.

## **Oiling the door spindle**

Oil the door spindle **every two months** as follows:

1. Clean the spindle with a non-fuzzing cloth.
2. Place two drops of oil in the bushing on the door of the steam sterilizer from the oil can included in the scope of delivery (art. no. 27515).

Instructions for oiling the door spindle are printed on the inside of the door of the steam sterilizer.

## Maintenance

---



### **NOTICE**

**Continuing operation beyond the maintenance interval can result in malfunctions in the device.**

- Maintenance should only be performed by trained and authorized customer services technicians, or stockist technicians.
  - Maintain the specified servicing intervals.
- 

Regular maintenance is vital to ensure reliable operation and value retention of the steam sterilizer. All function and safety-relevant components and electrical units must be checked during maintenance and replaced where necessary. Maintenance is performed in accordance with the maintenance instructions pertinent to this steam sterilizer.

Arrange for regular maintenance in 2 year intervals or after 2000 program cycles. The steam sterilizer will issue a maintenance message at the relevant time.

# 12 Pause times

## Frequency of sterilization

Pause times between the individual programs are not necessary, as the sterilization chamber is maintained permanently at the same temperature. After the end/abort of the drying time and removal of the sterilized equipment, you can load the steam sterilizer again and start a new program.

## Decommissioning

When decommissioning the steam sterilizer for a long pause (e.g. due to holiday), proceed as follows:

1. Switch off the steam sterilizer at the power switch.
2. After deactivating, wait until the pressure display manometer of the deactivation pressure shows zero bar.
3. Remove the power plug from the socket and if necessary, allow the steam sterilizer to cool.
4. Empty the internal storage tank.
5. Shut off if present, the water inflow of the water treatment unit.

## Emptying the double jacket

You have the option of draining the water in the double jacket steam generator easily via the Draining program. In order to do so, the steam sterilizer is heated once, building up pressure in the double-jacket so that the water can be drained fully from the double jacket steam generator.

1. Switch on the steam sterilizer at the power switch.
2. Working in the **Programs & Tests** menu, select the Draining program and press START.



3. Switch off the steam sterilizer in the program end window "Draining successful" so that the steam sterilizer does not feed water back into the double jacket.

## Transport



### CAUTION

**Danger of injury from incorrect carrying.**

**Lifting and carrying too heavy a load can result in spinal injury. Failure to comply with these provisions can result in crushing.**

- The device should always be carried by two people.
- Use the suitable carrying straps to carry the device.
- Please note that the distance between the base plate and the setup surface is low.
- Please ensure that you comply with the transport instructions.

Please comply with the following during transport, within a room or the practice:

- ▶ Decommission the steam sterilizer, see: [Decommissioning](#) [▶ page 59].
- ▶ Remove the connection hoses connected on the rear of the device.
- ▶ Should you wish to leave the mount and trays or cassettes in the chamber during transport, protect the surface of the round blank. To do so, place some foam or bubble wrap between the round blank and mount.
- ▶ Close the steam sterilizer door before moving it.

### Emptying the double jacket

You have the option of draining the water in the double jacket steam generator easily via the Draining program. In order to do so, the steam sterilizer is heated once, building up pressure in the double-jacket so that the water can be drained fully from the double jacket steam generator.

1. Switch on the steam sterilizer at the power switch.
2. Working in the **Programs & Tests** menu, select the Draining program and press START.



3. Switch off the steam sterilizer in the program end window "Draining successful" so that the steam sterilizer does not feed water back into the double jacket.

### Transport within the practice

Please comply with the following during transport, within a room or the practice:

- ▶ Decommission the steam sterilizer, see section [Decommissioning](#) [▶ page 59].
- ▶ Remove the connection hoses connected on the rear of the device.
- ▶ Should you wish to leave the mounts and tray or cassettes in the chamber during transport, protect the surface of the round blank. To do so, place some foam or bubble wrap between the round blank and mount.
- ▶ Close the steam sterilizer door before moving it.

### **Transport over long-distance / dispatch**



For transport over longer distances, during the danger of frost and / for despatch or during maintenance, an authorized person must prepare the steam sterilizer according to instructions and empty the double-jacket steam generator entirely.

### **Recommissioning after relocation**

When recommissioning after a move, proceed as with the first commissioning; see technical manual.

# 13 Malfunctions

Not all notifications on the display are malfunction messages. Warnings and malfunction messages are issued on the display with an event number. This number serves identification purposes.

	Type of the display notification	Explanation
	Messages	A number of notifications are messages providing information. Messages are not malfunction messages or warnings. They support the operation of the steam sterilizer.
	Warnings	Warning messages are displayed when necessary. These contain instructions which apply to you, the operator. Warning messages are not malfunction messages. They help to ensure malfunction-free operation and to recognize undesirable situations. Comply with these warnings early in order to avoid malfunctions.
	Malfunction messages	Malfunction messages are issued when it is not possible to ensure safe operation or safety of sterilization. These can appear on the display shortly after switching on the device or during a program run. If a fault occurs during a program run, the program will be aborted. Aborting a program before the drying phase means that the load is unsterile. If necessary, repack the load and repeat the sterilization for the sterilization material affected.



## WARNING

**Danger of infection from early program abort**

**Aborting a program before the drying phase begins means that the load is unsterile. This endangers the health of your patients and practice team.**

- If necessary, repack the load and repeat the sterilization for the sterilization material affected.

### **Before contacting customer services**

Ensure that you have complied with all instructions relating to a warning or malfunction message issued on the display of the steam sterilizer. The following table contains a summary of the most important events. Should you be unable to find the relevant event in the table below, or your efforts do not redress the problem, you can contact your nearest stockist or an authorized MELAG customer service provider. To enable us to give the best possible service, please have your steam sterilizer serial number and a detailed description of the fault to hand.

## Messages

Incident	Possible causes	What you can do
M248	The vacuum test was performed, despite residual moisture in the chamber or with a load.	Repeat vacuum test, when steam sterilizer is cold and empty

## Warnings

Incident	Possible causes	What you can do
W63 W65	With an internal storage tank for feed water: water of insufficient quality was poured into the storage container (>60 µS/cm) With a water quality: With a water treatment unit: mixed-bed resin in the water treatment unit exhausted	Empty and clean the storage tank and fill with feed water of sufficient quality Replace the mixed-bed resin in the water treatment unit
W67 W68	Waste water side of the storage tank (left-hand chamber) is full With connection of the waste water connection to a siphon: Waste water hose kinked	Empty the waste water side Check installation of waste water hose
W72 W73 W74 W75	The feed water quality declines (>40 µS/cm), the mixed-bed resin will soon be exhausted	You can still perform all work with the steam sterilizer and should fill fresh feed water or replace the mixed-bed resin cartridge as soon as possible.
W76	See W67	
W79 W80	The waste water side of the internal storage tank was not emptied or emptied incompletely.	Empty the waste water side of the storage tank (left-hand chamber) completely
W128	Waste water hose kinked or installed sagging	Check the waste water hose: The hose must be installed at a constant decline without sagging.
W129	Steam sterilizer overloaded Poor electricity supply (under-sized domestic installation to the socket, damaged socket, multiple devices on a single socket/fuse)	Check the load Check the network supply
W192	The internal storage tank (right-hand chamber) must contain sufficient water for the subsequent rinsing process.	Fill the storage tank with feed water or ensure the water supply of the water treatment unit
W192	The waste water side of the internal storage tank (left-hand chamber) must be empty for the subsequent rinsing process.	Empty the waste water side of the storage tank (left-hand chamber) completely
W351	2 years have passed / 2000 sterilization programs have been conducted since first commissioning or the last maintenance	Contact an authorized customer services provider or your stockist to arrange servicing. The device can still be started.
W377	The log printer is not connected correctly	Connect the log printer in accordance with the separate operating manual
W386	The internal log memory of the steam sterilizer is almost completely full	Output all logs on any output medium, e.g. a CF card via the <b>Log output</b> menu.

## Malfunction messages

Incident	Possible causes	What you can do
F61	With an internal storage tank for feed water: no water in the storage tank With a water treatment unit: does not produce any water because the water inflow tap is not open	Fill the internal storage tank (right-hand chamber) Open the water inflow for the water treatment unit
F64	See W63	
F78	See W79	

Incident	Possible causes	What you can do
F102	See W128	
F113	Steam sterilizer switched off during a running program	Do not switch off the steam sterilizer at the power switch whilst a program is running
	The power plug has been disconnected, power outage in the building supply	Check the power plug and building power plug; operate the steam sterilizer on a separate electrical circuit
F124 F125 F126	See W134	
F136	Ambient temperature too high, ventilation slots covered, minimum clearance to the sides not maintained	Comply with the setup conditions
	Door remains open permanently	Close the door
F175 F176	ACOUT1 main heating / ACOUT2 control heating, electrical supply interrupted, FOY1+ FOY2 can occur in alternation.	<ol style="list-style-type: none"> <li>1. Switch off the device and press the overheat control reset button back in.</li> <li>2. Acknowledge the malfunction message.</li> <li>3. Switch the steam sterilizer off and then back on again.</li> <li>4. Proceed with sterilization / perform an empty sterilization run.</li> </ol>
F183	See F124	
F414	With a direct water water connection: Waste water hose kinked	Check the w for kinks or pinching
	Ambient temperature too high, installed steam sterilizer receives too little or no cooling air	Ensure sufficient air inflow on the rear of the steam sterilizer; maintain the set-up conditions.
	Steam sterilizer is overloaded	Maintain maximum load quantity
	The steam sterilizer was operated without a mount with the result that e.g. the textile package has come into direct contact with the chamber and absorbed a large amount of condensate	Use a mount, comply with the instructions for the correct loading of the steam sterilizer
	Cooling air ingress holes on the base plate are covered e.g. by paper.	Remove any objects (e.g. paper) from below the steam sterilizer.
	Packaging residue chokes the pressure release nozzle in the sterilization chamber	Check for packaging residue in sterilization chamber
F428 F439	With a direct water water connection: Waste water hose kinked	Check the waste water hose for kinks or pinching
	Poor installation (multiple devices attached to a single siphon, sagging waste water hose)	Comply with the setup conditions
	Packaging residue chokes the pressure release nozzle in the sterilization chamber	Check for packaging residue in sterilization chamber



# 14 Technical data

Device type	Vacuklav 41 B+ Evolution	Vacuklav 43 B+ Evolution
Device dimensions (HxWxD)	56.5 x 47 x 57.5 cm	56.5 x 47 x 69 cm
Chamber diameter/depth	Ø 25 cm   35 cm	Ø 25 cm   45 cm
Chamber volume	18.4 litres	23.8 litres
Empty weight	60 kg	69 kg
Operating weight	81 kg	91 kg
Electricity supply	220-240 V, 50/60 Hz, 3400 W	
Building fuses	16 A, FI protection 30 mA	
Waste heat (with maximum load)	1.7 kWh	
Noise emission	64 dB(A)	
Ambient temperature	5-40 °C (ideal range 16-26 °C)	
Relative humidity	max. 80% at 31 °C, decreases in a linear fashion up to max. 50% relative humidity at 40 °C	
Max. height	2000 m	
Length of the power cable	2 m	
Degree of protection (following IEC 60529)	IP20	
CE marking	CE 0197, CE 0035	
<b>Feed water connection</b>		
Water quality	DIN EN 13060, Appendix C	
Min. flow pressure	1.5 bars at 3 l/min	
Min. static water pressure	2 bar	
Max. static water pressure	10 bar	
Max. water consumption	0.74 L	0.83 L
<b>Waste water connection</b>		
Max. through-flow volume	1.5 L	1.5 L
Max. water temperature	98 °C	98 °C

## 15 Accessories and spare parts

You can obtain the specified articles and an overview of further accessories from your stockist.

Category	Article	Order no.	
Mounts	Mount C "Plus" for 6 trays or 3 MELAstore-Boxes 100	81375	81385
	Mount D "Plus" for 2 MELAstore boxes 200 or 2 MELAstore boxes 100 and 2 narrow trays	82645	82655
	Mount E "Plus" for 6 trays (standard) and 2 narrow trays.	82400	82700
	Mount F "Plus" for 3 MELAstore-Boxes 100 and 2 narrow trays	82665	82675
Trays	Tray	00280	00230
	Tray, narrow	01320	01310
Sterilization container with a single-use paper filter in accordance with DIN EN 868-8	15K (18 x 12 x 4.5 cm)	01151	
	15M (35 x 12 x 4.5 cm)	01152	
	15G (35 x 12 x 8 cm)	01153	
	17K (20 x 14 x 5 cm)	01171	
	17M, for 45 cm chamber depth (41 x 14 x 5 cm)	---	01172
	17G, for 45 cm chamber depth (41 x 14 x 9 cm)	---	01173
	23M, for 45 cm chamber depth (42 x 16 x 6 cm)	---	01231
	23G, for 45 cm chamber depth (42 x 16 x 12 cm)	---	01232
	28M (32 x 16 x 6 cm)	01284	
	28G (32 x 16 x 12 cm)	01285	
MELAstore System	MELAstore-Tray 50 (18 x 11.8 x 3 cm)	01180	
	MELAstore-Tray 100 (27.5 x 17.6 x 3 cm)	01181	
	MELAstore-Tray 200 (27.5 x 17.6 x 4.3 cm)	01182	
	MELAstore-Box 100 (31.2 x 19 x 4.6 cm)	01191	
	MELAstore-Box 200 (31.2 x 19 x 6.5 cm)	01192	
Test body system	MELAcontrol consisting of a Helix test body and 250 indicator strips	01080	
	MELAcontrol consisting of a Helix test body and 40 indicator strips	01075	
Water treatment	MELAdem 40 ion exchanger	01049	
	MELAdem 47 reverse osmosis unit	01047	
For documentation:	MELAflash CF card	01043	
	MELAflash card reader	01048	
	Label-Printer MELAprint 60	01160	
	Network cable (cross-over), 2 m	15813	
	Network cable (cross-over), 5 m	15814	
	Network cable (cross-over), 10 m	15815	
Other	Water stop (leakage water detector)	01056	
	Surface-mounted siphon	37410	
Category	Article	Order no.	
Spare Parts	1x Oil for door lock socket	27515	

## Glossary

### **Air leakage**

An air leakage is a location through which air can pass in and out without this being desired. Verification of the leakage serves to prove that the volume of air ingress in the chamber during the vacuum phase does not exceed a value which would prevent steam penetration of the sterilizer load and that the air leakage does not cause the possible contamination of the sterilizer load during the drying phase.

### **AKI**

Abbr.: working group instrument preparation ("Arbeitskreis Instrumentenaufbereitung")

### **Authorized personnel**

An authorized personnel can be medical stockists, depot technicians or MELAG-authorized customer services trained by MELAG.

### **Batch**

Collection of sterilization material which has been processed together in the same sterilization program.

### **BGV A1**

BGV is the abbreviation for Berufsgenossenschaftliche Vorschriften (regulations from a professional association). A1 stands for principles of prevention

### **Bowie & Dick test**

Steam penetration test with a standard test package; described in DIN EN 285; the test is recognized in the large-scale sterilization industry.

### **CF card**

Abbr.: "Compact Flash Card"; a memory card for digital data with a compact size. CF is a standard.

### **Condensate**

Fluid (e.g. water) produced by the cooling of and resultant separation from the vaporous state.

### **Conductivity**

Conductivity is the opposite of electrical resistance; measured in micro-Siemens/centimetre ( $\mu\text{S}/\text{cm}$ ); the greater the amount of dissolved matter in the water, the better it can conduct electrical current and thus the higher its conductivity.

### **Corrosion**

The chemical alteration or destruction of metal materials by water and chemicals

### **Delay in boiling**

This refers to the phenomenon that it is possible under certain circumstances to heat a fluid beyond its boiling point without them boiling. This represents an unstable state; even low-level agitation can

produce a large bubble within the shortest period, which expands explosively.

### **Demineralized water**

Water without the minerals usually found in normal spring or tap water; is produced through ion exchange of normal tap water. It is used here as feed water.

### **DGSV**

Abbr.: Deutsche Gesellschaft für Sterilgutversorgung (German Society German Society for Sterile Supply). The DGSV training centres are specified in DIN 58946, part 6 as "Requirements of personnel".

### **DIN 58946-7**

Standard – sterilization - steam steam sterilizers - part 7: Building requirements and requirements placed on the operating agents and the operation of steam sterilizers in the health-care branch

### **DIN 58953**

Standard – sterilization, sterile equipment supply

### **DIN EN 13060**

Standard – small steam sterilizers

### **DIN EN 867-5**

Standard – non-biological systems for use in sterilizers – part 5: The determination of indicator systems and test bodies for the performance inspection of type B and type S small sterilizers.

### **DIN EN ISO 11140-1**

Standard – the sterilization of products for use in medical treatment – chemical indicators – part 1: General requirements

### **DIN EN ISO 11607-1**

Standard - packaging for medical devices to be sterilized in the final packaging - Part 1: Requirements placed on materials, sterile barrier systems and packaging systems

### **Distilled water**

From the Latin aqua destillata; also referred to as aqua dest; water which to a great extent is free from salts, organic material and micro-organisms, is produced from normal tap water or pre-cleaned water through the process of distillation (evaporation and subsequent condensation). It is used here as feed water.

### **Double-jacket steam generator**

Serves the quick generation of steam outside the sterilization chamber, surrounds the sterilization chamber

**Dynamic pressure test of the sterilization chamber**

Serves to prove that the rate of pressure variations during a sterilization cycle does not exceed a particular value which could result in the damage of the packaging material. [see also DIN EN 13060]

**Empty chamber test**

Test run without a load, performed to assess the performance of a sterilizer without the influence of a load; facilitating verification of the temperatures maintained in comparison to the temperatures set. [see also DIN EN 13060]

**Evacuation**

Creation of a vacuum in a vessel

**Feed water**

Feed water is required to produce steam for sterilization. Guide values for water quality in accordance with DIN EN 285 / DIN EN 13060 – Appendix C

**Fractionated vacuum procedure**

A technical procedure in steam sterilization; the repeated evacuation of the sterilization chamber in alternation with steam injection.

**FTP**

Abbr.: (File Transfer Protocol) is a data transmission procedure serving to transport data from the internet. This data can include programs, files or even information. Special FTP programs (FTP clients) serve to load the data onto a server.

**Heat-up phase**

The time required after the steam sterilizer has been switched on / after the start of a sterilization program, to heat the double-jacket steam generator before the sterilization procedure starts. The duration is dependent on temperature at which sterilization takes place.

**Hollow body A**

See product with narrow lumen

**Hollow body article B**

See simple hollow body

**MELAG network adapter**

Ethernet printer module for the MELAprint 42 log printer; a printer connection on one side and a network connection on the other

**Mixed loads**

wrapped and unwrapped sterilization material within a single load

**Multiple wrapping**

e.g. wrapped instruments sealed in a double layer of film or wrapped in film and placed in an additional container or a container wrapped in textiles.

**Network cable (crossover)**

A crossover cable connects two computers (through network cards) directly without the use of a hub/switch. This type of connection corresponds with the network connection of the steam sterilizer in the practice network. The crossover cable does not run in parallel between the connectors, rather certain skimmers are crossed.

**Porous**

Permeable for fluids and air e.g. textiles

**Porous full load**

Serves to prove that the values set on the control satisfy the necessary sterilization conditions in porous loads with a maximum mass for which the sterilizer is designed in accordance with DIN EN 13060 [see also DIN EN 13060]

**Porous partial load**

Serves to prove that the values set on the control allow steam to enter the pre-determined test package quickly and equally [see also DIN EN 13060]

**Process evaluation system**

Also known as the self-monitoring system – this observes itself and compares the various sensors during a current program.

**Product with narrow lumen**

An article open on one side to which the following applies:  $1 \leq L/D \leq 750$  and  $L \leq 1500$  mm or an article with an opening on both sides which is:  $2 \leq L/D \leq 1500$  and  $L \leq 3000$  mm and which does not correspond to a hollow body article B; L...length of hollow body article; D...Diameter of hollow body article [see also DIN EN 13060]

**RKI**

Abbr.: "Robert-Koch-Institute". It is one of the most important bodies for the safeguarding of public health in Germany.

**Simple hollow bodies**

An article open on one side to which the following applies:  $1 \leq L/D \leq 5$  and  $D \geq 5$  mm or an article with an opening on both sides which is:  $2 \leq L/D \leq 10$  and  $D \geq 5$ ; L...hollow body article length; D... hollow body article diameter [see also DIN EN 13060]

**Single wrapping**

Wrapped once e.g. instruments sealed in foil – in opposition to: Multiple wrapping

**Soft sterilization packaging**

e.g. a paper bag or transparent sterilization packaging.

**Solid**

Without hollows or gaps, solid, compact, closed

**Solid load**

Serves to prove that the necessary sterilization conditions have been reached within the entire load with the values set in the control. The load must represent the largest weight of massive instruments designed for sterilization in a sterilizer in accordance with DIN EN 13060. [see also DIN EN 13060]

**Sterile barrier system**

A closed minimum packaging which prevents the entrance of micro-organisms e.g. through sealing bags, sealed and re-usable containers and folded sterilization towels etc.

**Sterilization chamber**

The interior of a sterilizer accommodates the sterilization material

**Sterilization material**

Unsterile, sterilizable material which is still to be sterilized.

**Sterilized equipment**

Also referred to as a batch: a load which has already been sterilized, i.e. is sterile

**TCP**

Abbr.: Transmission control protocol: refers to a standard protocol for connecting computers and networks.

**Vacuum**

In common parlance, an area devoid of all material  
□ In the technical sense: volumes with a reduced gas pressure (at least air pressure)

**VDE**

Abbr. (German): "Verband der Elektrotechnik, Elektronik und Informationstechnik e.V." (Alliance of the Electronics, Electrotechnical and IT Industry).

## MELAG Medizintechnik oHG

Geneststraße 6-10  
10829 Berlin  
Germany

E-Mail: [info@melag.com](mailto:info@melag.com)  
Web: [www.melag.com](http://www.melag.com)

Responsible for content: MELAG Medizintechnik oHG  
We reserve the right to technical alterations

Your stockist

