

# User manual

**Vacuklav<sup>®</sup> 23 B+**

**Vacuklav<sup>®</sup> 31 B+**

Steam sterilizer

From software version 5.15



---

Dear Dr

We should like to extend our thanks for the expression of trust in our company which you have displayed through the purchase of this MELAG device.

As an owner-run and operated family concern founded in 1951, we have a long history of successful specialization in hygiene products for practice-based use. Our focus on quality, highest standards of operational reliability and innovation has established MELAG as the world's leading manufacturer in the area instrument treatment and hygiene.

You, our customer are justified in your demand for the best products, quality and reliability. Providing "**competence in hygiene**" and "**quality - made in Germany**", we guarantee that these demands will be met. Our certified quality management systems is subject to close monitoring: one instrument to this end is our annual multi-day audit conducted in accordance with ISO 13485 and ISO 9001. This guarantees that all MELAG products are manufactured and tested in accordance with strict quality criteria.

The MELAG management and team.

## General notes

Please read this user manual carefully before commissioning the device. The manual includes important safety information. The functionality and value-retention of this sterilizer depends on the care accorded to it.

Please store this user manual carefully and in close proximity to your sterilizer. It represents a component of the product.

## User group



This manual is addressed to doctors, their assistants and service departments.

## Validity

This manual is valid for the steam sterilizer Vacuklav 23 B+ und Vacuklav 31 B+.

## About this manual













### Symbols used

| Symbol   | Explanation  |
|--|--|
|   | Indicates a dangerous situation, which if not avoided, could entail slight to life-threatening injuries.                                   |
|   | Draws your attention to a situation, which if not avoided, could result in damage to the instruments, the practice fittings or the device. |
|  | Draws your attention to important information.   |

### Formatting rules

| Symbol                   | Explanation   |
|--------------------------|---|
| <b>Universal Program</b> | Words or phrases appearing on the display of the sterilizer are marked as software citations. |
| Chapter 6 - Logging      | Reference to another text section within these instructions.                                  |
| Figure 1/5               | Reference to a detail in a figure – in the example, to part no. 5 in Figure 1.                |

## Symbols on the device

| Symbol  | Erklärung   |
|---|---|
|    | Manufacturer of the medical device  |
|    | Date of manufacture of the medical device   |
|    | Serial number of the medical device by the manufacturer   |
|    | Article number of the medical device  |
|    | This User Manual contains important safety information. Failure to comply of the safety instructions could result in human and material damage.   |
|   | Please read this user manual carefully before commissioning the device. The manual includes important safety information. The functionality and value-retention of this sterilizer depends on the care accorded to it. Please store this user manual carefully and in close proximity to your sterilizer. It represents a component of the product.   |
|  | In affixing this CE mark, the manufacturer declares that this medical product fulfils the basic requirements of the medical device directive. The four-digit number confirms that this is monitored by an approved certification agency.  |
|  | In affixing this CE mark, the manufacturer declares that this medical product fulfils the basic requirements of the pressure device directive. The four-digit number confirms that this is monitored by an approved certification agency.   |
|  | The symbol of the struck out waste bin identifies a device that may not be disposed in the domestic waste. The vendor is responsible for appropriate disposal of the device - it must be delivered to the vendor to be disposed of. With the designation of an apparatus with this symbol, the manufacturer furthermore declares that he satisfies all requirements of the law concerning the release, redemption and environmentally sound disposal of electric and electronic appliances.<br>MELAG devices are synonymous for long-term quality. When you eventually need to decommission your MELAG device, we offer a special disposal service. Simply contact your stockist. |
|  | Indication of the scale of the chamber volume   |
|  | Operating temperature of the device   |
|  | Operating pressure of the device  |

## Scope of delivery

### **Standard scope of delivery**

- Vacuklav 23 B+ or Vacuklav 31 B+
- User manual
- Technical manual
- Guarantee
- Manufacturer's inspection report
- Declaration of conformity medical products directive
- Declaration of conformity pressure device directive
- Installation / set-up protocol
- Mounts for trays and cassettes
- Tray jack
- Hose for emptying the interior water storage tank
- TORX key for removing the carrying strap
- Lever for emergency opening of the door
- Key for the filter inside the chamber
- 2 Replacement device fuses on the door interior of the sterilizer

### **Optionally**

- Trays
- Standard tray cassettes and jack
- Additional mounts

## Table of contents

|  |           |   |           |
|--|-----------|---|-----------|
| <b>Chapter 1 – Device description</b> .....        | <b>8</b>  | Batch-related checks.....                               | 33        |
| Intended Use .....                                 | 8         | Vacuum test.....  | 33        |
| Views of the device.....                           | 9         | Bowie & Dick test.....                                  | 34        |
| Operating panel.....                               | 10        | Checking the quality of the feed water.....             | 35        |
| Mountings for the load.....                        | 10        | Check pre-heating temperature of the chamber.....       | 35        |
| <b>Chapter 2 – Installation</b> .....              | <b>11</b> | <b>Chapter 7 - Maintenance</b> .....                    | <b>36</b> |
| Electrical connection.....                         | 11        | Checks and cleaning.....                                | 36        |
| Feed water supply .....                            | 11        | Avoiding staining.....                                  | 37        |
| Waste water connection .....                       | 11        | Replacing the door seal .....                           | 37        |
| Record of installation and set-up .....            | 11        | Aligning the door seal sealing lip.....                 | 38        |
| <b>Chapter 3 – Initial start-up</b> .....          | <b>12</b> | Replacing or sterilizing the sterile filter .....       | 39        |
| Switching on the sterilizer .....                  | 12        | Cleaning the filter in the chamber.....                 | 40        |
| Opening and closing the door.....                  | 12        | Maintenance .....                                       | 41        |
| Providing feed water .....                         | 12        | <b>Chapter 8 – Operating Pauses</b> .....               | <b>41</b> |
| Setting the date and time.....                     | 13        | Sterilization times.....                                | 41        |
| <b>Chapter 4 - Sterilizing</b> .....               | <b>14</b> | Operating pauses.....                                   | 41        |
| Preparing the sterilization material .....         | 14        | Decommissioning.....                                    | 41        |
| Loading the sterilizer.....                        | 15        | Recommissioning after relocation .....                  | 41        |
| Selecting the program.....                         | 18        | <b>Chapter 9 – Description of function</b> .....        | <b>42</b> |
| Selecting automatic pre-heating .....              | 19        | The sterilization procedure.....                        | 42        |
| Starting the program.....                          | 19        | Type of the feed water supply .....                     | 42        |
| Selecting additional drying.....                   | 20        | Internal process monitoring.....                        | 42        |
| Program run.....                                   | 20        | Program .....   | 42        |
| Sterilization phase is ended.....                  | 20        | <b>Chapter 10 – Malfunctions</b> .....                  | <b>46</b> |
| Drying phase .....                                 | 21        | Before you call customer service .....                  | 46        |
| Program end.....                                   | 21        | Opening the Emergency door during a power failure ..... | 53        |
| Manual program abort .....                         | 21        | Changing the device fuses.....                          | 54        |
| Displaying the daily batch counter .....           | 23        | <b>Glossary</b> .....                                   | <b>55</b> |
| Displaying the total batch counter.....            | 23        | <b>Technical Data</b> .....                             | <b>57</b> |
| Removing the sterilized equipment.....             | 24        | <b>Accessories</b> .....                                | <b>58</b> |
| Storing sterile equipment.....                     | 24        |   |           |
| <b>Chapter 5 - Logging</b> .....                   | <b>25</b> |   |           |
| Batch documentation .....                          | 25        |   |           |
| Output media .....                                 | 25        |   |           |
| Outputting logs immediately and automatically..... | 28        |   |           |
| Subsequent log output.....                         | 29        |   |           |
| Displaying the log memory .....                    | 30        |   |           |
| Deleting logs in the internal log memory.....      | 30        |   |           |
| Reading logs correctly .....                       | 31        |   |           |
| <b>Chapter 6 – Functional Checks</b> .....         | <b>33</b> |   |           |
| Automatic functional checks .....                  | 33        |   |           |
| Manual functional checks .....                     | 33        |   |           |

## Safety Instructions

When operating the sterilizer, please observe the following safety instructions as well as those contained in subsequent chapters.

Use the device only for the purpose named in the user manual.

- Never use this sterilizer to sterilize any fluids.

Power cable and mains socket

- Never damage or alter the plug or power cable.
- Never operate the sterilizer if the plug or power cable are damaged.
- Never unplug by pulling on the power cable. Always take a grip on the plug.

Set-up installation and commissioning

- The sterilizer should only be set-up, installed and commissioned by MELAG authorized persons.
- The connections for electrical provision and water supply and discharge must be set-up by trained personnel.
- In accordance with current VDE specifications, the sterilizer is unsuitable for operation in areas exposed to the danger of explosion.
- The sterilizer is conceived for use outside the patient area. The device should be located a minimum of 1.5 m radius away from the treatment area.
- Observe all the information contained in the technical manual during commissioning.
- Documentation media (computer, CF card reader, etc.) must be placed in such a way that they cannot come into contact with liquids.
- Failure to comply with the set-up conditions can result in malfunctions or damage to the sterilizer and/or human injury.

Preparation and sterilization

- Follow the manufacturer instructions of your textile articles and instruments regarding their treatment and sterilization.
- Observe the relevant standards and directives applicable to the treatment and sterilization of textiles and instruments e.g. from the RKI, and DGSV.
- Only ever use packaging material and systems which have been cleared by their manufacturer for steam sterilization (consult the manufacturer's instructions).
- Only ever operate the steam sterilizer with a sterile filter inserted.

Program abort

- Please observe that depending on the time of the program abort, opening the door following a program abort can lead to hot steam leaving the chamber.
- Depending on the time of the program abort, it is possible that the load is unsterile. Observe the clear instructions on the sterilizer display. It may be necessary to re-pack and re-sterilize the sterilization material.

Removing the sterilized equipment

- Never use force to open the door.
- Use a tray jack to remove the tray. Never touch the sterilized equipment, the chamber or the door with bare hands. The components are hot.
- Check the packaging on the sterilized equipment for damage when removing it from the sterilizer. Should the packaging be damaged, re-pack the sterilization material and re-sterilize it.

**Maintenance**

- Maintenance should only be performed by authorized personnel.

**Carrying the sterilizer**

- The sterilizer should always be carried by two people.
- Use the correct carrying strap to carry the sterilizer.

**Malfunctions**

- Upon the incidence of repeated malfunction messages in the sterilizer, turn off the sterilizer and if necessary, inform your stockist.
- The sterilizer may only be serviced by authorized personnel.
- The sterile filter must be sterilized or replaced following a power outage suffered in over-pressure or following the incidence of the malfunction message **Malfunction 32**.

# Chapter 1 – Device description

---

## Intended Use

The sterilizer is designed for application in a medical context, e.g. clinics and medical and dental practices. According to DIN EN 13060, this sterilizer is a Class-B-sterilizer. As a universal sterilizer, it is suited to highly-demanding sterilization tasks. It can be used to sterilize instruments with a low inner diameter and transfer instruments - both wrapped or unwrapped - and large quantities of textiles.



### **DANGER**

**The sterilization of fluids can result in a delay in boiling, which could result in damage to the sterilizer and burns.**

- Never use this sterilizer to sterilize any fluids. It is not licensed for the sterilization of fluids.
- 



### **WARNING**

**Failure to observe these provisions can result in damage or can compromise safety.**

- Only ever use the sterilizer for the applications as foreseen in the technical documentation and only in connection with the devices and components as recommended by MELAG.
  - As with the preceding instrument treatment and in accordance with §2 MPBetreibV, the sterilization of instruments and textiles using this sterilizer may only be carried out by competent personnel.
  - When conducting sterilization procedures, only use instruments, packaging and textiles which the manufacturer has cleared for steam sterilization.
-



Views of the device

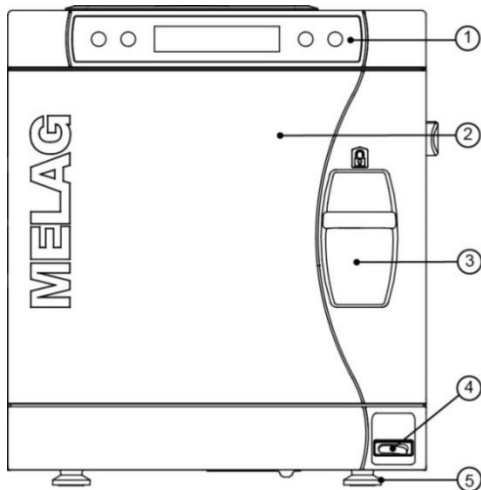

1. Operating and display panel
2. Door, pivots to the left
3. Sliding closure grip
4. Power switch
5. Front device foot (adjustable)
6. Connection for emptying the storage tank waste water
7. Connection for emptying the storage tank feed water
8. Serial data and printer connection (RS232)\*
9. Fuses – 2x 16A/gRL

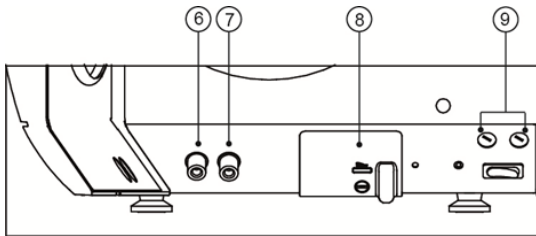

\*hidden behind the white cover

Fig. 1: Device view front side

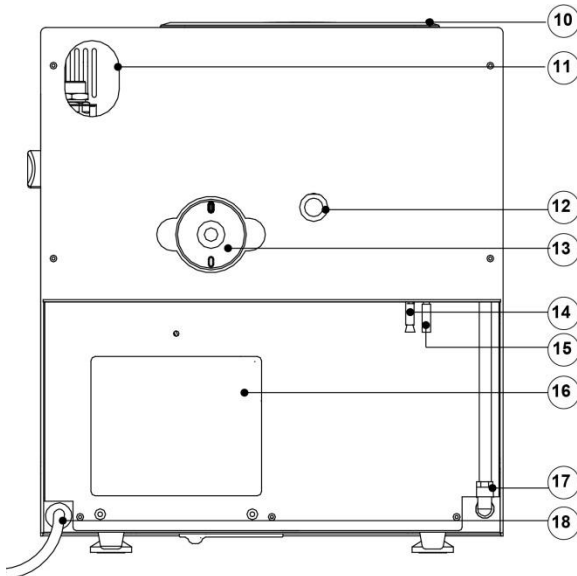

10. Tank lid
11. Slot for optional upgrade with the safety combination EN 1717
12. Spring safety valve
13. Sterile filter
14. One-way discharge (optional)
15. Emergency overflow hose
16. Cooler
17. Purified feed water inlet for water treatment unit
18. Power supply cord

Fig. 2: Device view rear panel



1. Mounting to hold trays/cassettes
2. Chamber
3. Door locking pin
4. Round blank
5. Door seal

Fig. 3: View of the interior

## Operating panel

The operating panel consists of a two-row alphanumerical LED display and four membrane keys.

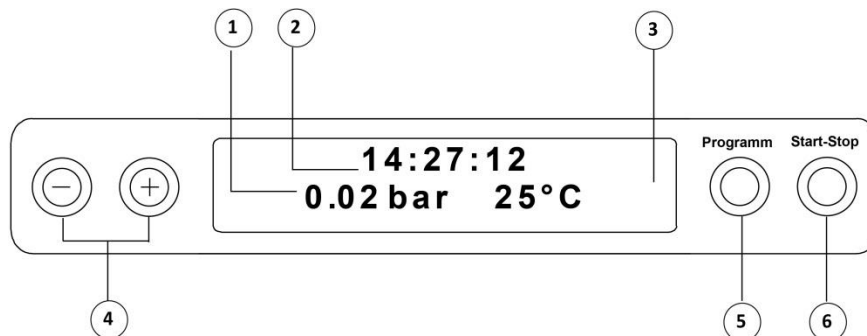

1. **2-line LC display**  
for program status display and parameter display.
2. Time (h:min:s)
3. Chamber pressure (bar) and (steam)- temperature (°C)
4. **Function key (-) and (+)**  
to select, set and display special functions:  
print, date/time, preheating, total batches, conductivity, acknowledge error, key (+) for unlocking the door.
5. Program selection key (P)  
to select the sterilization programs/test programs and select or set options (submenus) of the special functions.
6. **Start – Stop key (S)**  
to start programs, terminate programs/drying as well as control of the special functions.

### Initial state

The display switches to the initial state after every activation of the device. This displays the current time and chamber pressure in bar and the (steam) temperature in °C.

## Mountings for the load

### Mount A

The sterilizer is always delivered with a mount for holding trays or cartridges.

The mounting (A) is standard and can hold either five trays or three standard tray cassettes rotated by 90°.

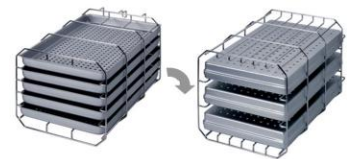

### Mount B

The mounting (B) can hold four standard tray cassettes or four trays.



### Mount D

The mounting (D) can hold two high cassettes (e.g. for implant cassettes) or four trays rotated by 90°.



## Chapter 2 – Installation

---



### PLEASE NOTE

The autoclave should only be set-up, installed and commissioned by MELAG authorized persons. Please observe the technical manual regarding installation. This contains all building-side requirements.

---

## Electrical connection

---



### DANGER

Incorrectly performed electrical connections can result in a short-circuit, fire, water damage and/or an electric shock.

**This could result in serious injury.**

- The connections for electrical provision and water supply and discharge must be set-up by trained personnel.
  - Observe the information regarding the installation and commissioning provided in the technical manual.
- 

Observe the following safety measures when dealing with the mains cable and plug:

- ▶ Never splice or change the power cable.
- ▶ Never bend or twist the power cable.
- ▶ Never pull on the mains cable to take the power plug out of the socket.
- ▶ Never place any heavy objects on the power cable.
- ▶ Ensure that the power cable does not become jammed (e.g. between the doors or windows)
- ▶ Never lead the cable along a source of heat.
- ▶ Never use any nails, paper fasteners or similar objects to fix the cable.
- ▶ Should the cable or plug become damaged, switch off the sterilizer. The power cable and plug should only be replaced by authorized personnel.
- ▶ Failure to observe these provisions can result in damage to the cable or plug and/or a fire or an electric shock. This could result in serious injury.

## Feed water supply

Steam sterilization requires distilled or demineralized/de-ionized water. Use only demineralized or distilled water according to DIN EN 13060, Appendix C. The feed water supply is provided either by an external water storage tank or with a water treatment unit see [Chapter 3 – Initial start-up](#). Detailed information regarding the connection to a water treatment unit is provided in the technical manual.

## Waste water connection

The waste water can either be collected in an internal storage tank (left side) and manually emptied or automatically drained via the one-way drain. An upgrade set for the tank drain is available for connecting the sterilizer to the effluent. Detailed information regarding the connection to the effluent is provided in the technical manual.

## Record of installation and set-up

The record of installation and set-up is to be completed by the responsible person and a copy be sent to both MELAG and the stockist as proof of correct set-up, installation and commissioning. This is a constituent part of any guarantee claim.

## Chapter 3 – Initial start-up

### Switching on the sterilizer

Turn the power switch on to power the sterilizer (page 9(4)).

After switching on the sterilizer with the power switch, the display shows in alternation to the initial state the message: **Unlocking door with key (+)**, if the door is closed.



#### PLEASE NOTE

The trays and all accessories must be removed from the chamber directly after the sterilizer having been switched on for the first time and before commissioning.

### Opening and closing the door

The door can only be opened when the display shows: **Acknowledge with '+' / Unlock door with '+' key**.

1. Press the (+) key. You can open the door after hearing an audible click.
2. Close the door with light pressure against the chamber flange and simultaneously press down the sliding-closure grip.

### Providing feed water

#### Using the internal storage tank

When feed water is supplied via the internal storage tank, this needs to be filled manually from time to time. The sterilizer will issue a maintenance message at the relevant time.

The internal storage tank holds max. 5 liters. This volume of feed water in the circulation system is sufficient for up to 7 sterilization runs.

To fill the storage tank with fresh feed water, remove the lid and fill the right-hand chamber of the storage tank with fresh feed water up to the MAX mark.



#### Setting the feed water supply on the sterilizer

The **INTERN** function must be set in order to enable feed water supply via the internal storage tank. The **EXTERN** function must be set in order to enable feed water supply via a water treatment unit.

1. Press the (+) and (-) keys simultaneously to select the set-up menu **Function**. The display shows the menu **Function: Last batch no.**
2. Navigate using the (+) or (-) keys until the display shows: **Function: Feed water test:**
3. Press the (P) key. The display shows the option currently set, e.g. pre-heating yes.
4. Press the (P) key again to change to the desired setting (**INTERN/EXTERN**).
5. Press the (S) key to save the setting and to leave the menu.

Repeated pressing of the (S) key enables you to leave the menu entirely and return to the display basic state.

## Using a water treatment unit

Observe the specifications in the technical manual when using a water treatment unit.



### PLEASE NOTE

Should you wish to use a water treatment unit from another manufacturer, please consult MELAG.

**Failure to comply with these provisions can result in damage to the sterilizer and/or human injury.**

## Setting the date and time

Correct batch documentation requires the correct date and time setting on the sterilizer. Ensure that you take into account the clock change in autumn and summer, as this is not adjusted automatically. Set the date and time as follows:

1. Press the (+) and (-) keys simultaneously to select the set-up menu **Function**. The display shows the menu **Function: Last batch no.**
2. Navigate in the Function menu using the (+) or (-) keys until the display shows:

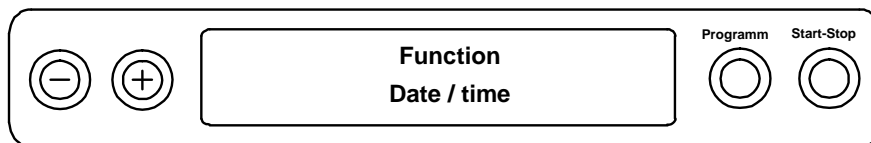

3. Press the (P) key to confirm. The current hour is displayed.
4. Choose one of the following setting possibilities using the (+) or (-) keys: Hours, minute, second, day, month, year.
5. To adjust the Hours parameter, press the (P) key to confirm. The current value flashes on the display.
6. You can increase or reduce the value using the (+) and (-) keys.
7. To save the value, confirm with the (P) key. The current value set no longer flashes on the display. To alter the other parameters, proceed in a similar fashion.
8. After ending the settings, press the (S) key to leave the menu. The display shows the menu **Function: Date / time**.
9. Repeated pressing of the (S) key enables you to leave the menu and the display returns to its basic state.

# Chapter 4 - Sterilizing

---

## Preparing the sterilization material

A significant prerequisite for safe disinfection and sterilization of sterilizing materials is the appropriate preparation, i.e. cleaning and maintenance of the sterilizing materials according to the manufacturer's instructions. Furthermore the materials, cleaning agents and processing procedure employed are of significance.



### PLEASE NOTE

Wherever possible, please ensure the separate sterilization of textiles and instruments in separate sterilization containers or sterilization packaging. This leads to better drying results.

---



### WARNING

- Only ever operate the steam sterilizer with a sterile filter inserted.
- 

## Treating instruments

Please ensure the following when treating used and brand-new instruments:

- ▶ Follow both the instrument manufacturer's instructions regarding treatment and sterilization and comply with the relevant standards and directives e.g. from the BGV A1, RKI and DGSV.
  - ▶ Clean the instruments exceptionally thoroughly e.g. using a washer-disinfector.
  - ▶ Rinse the instruments after washing and disinfecting, where possible with de-mineralized or distilled water and then dry the instruments thoroughly with a clean, non-fuzzing cloth.
  - ▶ Use only those care agents suitable for steam sterilization. Consult the manufacturer of the care agents.
- 



### DANGER

The incorrect treatment of instruments could result in any dirt residue being loosened during sterilization. The presence of residual disinfection and cleaning fluids results in corrosion.

**The use of unsuitable care agents e.g. water repellent agents or oils impermeable to steam could result in unsterile instruments. This represents a danger to the health of both patients and yourself.**

**This could result in increased maintenance requirements and a restriction of the sterilizer function.**

- Comply with the treatment instructions contained in these instructions.
- 

When using ultra-sound devices, care equipment for hand pieces and washing and disinfection devices, please observe the manufacturer's treatment instructions.

## Treating textiles

Please observe the following points when treating textiles and putting the textiles in sterilization containers:

- ▶ Observe and comply with both the manufacturer's instructions of the textiles regarding treatment and sterilization as well as the relevant standards and directives e.g. from the RKI, and DGSV.
- ▶ Arrange the folds in the textiles parallel to each other.
- ▶ Stack textiles vertically wherever possible and not too closely together in the sterilization chamber. This enables the development of flow channels.
- ▶ Retain the vertical stacking system when packing textiles in the sterilization container.
- ▶ If textile packages do not remain together, wrap the textiles in sterilization paper.
- ▶ Only ever sterilize dry textiles.
- ▶ The textiles must not be permitted to come into direct contact with the floor or walls of the sterilization chamber; otherwise they will become saturated with condensate.



### DANGER

Steam penetration of the textile package can be restricted and/or will produce poor drying results. The textiles could not be sterilized.

**This could endanger the health of patient and practice team.**

- Comply with the treatment instructions contained in these instructions.
- 

## Loading the sterilizer

Only when correctly loaded is effective sterilization and good drying possible.

Ensure the following during loading:

- ▶ Insert trays or cassettes in the chamber only with their appropriate mount.
- ▶ Use perforated trays such as those from MELAG. Only in this way can the condensate drain off. The use of a non-perforated base or half-shell to accept the sterilization material can result in poor drying results.
- ▶ The use of paper tray inserts can result in poor drying results.

## Packaging

Only ever use packaging materials and systems (sterilization barrier systems) corresponding to the standard DIN EN ISO 11607-1.

The correct use of suitable packaging is important in achieving successful sterilization results.

You can use re-usable rigid packaging systems such as e.g. standard tray cassettes or soft packaging such as transparent sterilization packaging, paper bags, sterilization paper, textiles or fleece.

## Closed sterilization containers

Please observe the following when using closed sterilization containers for sterilization material:

- ▶ Use aluminium sterilization containers. Aluminium retains and conducts heat and thus improves drying.
- ▶ Closed sterilization containers must be either perforated or have a valve on at least one side - optimally the bottom.
- ▶ Wherever possible, please ensure that sterilization containers are stacked on top of those of identical size, so that the condensate can run down their sides.

***Our TIP: MELAG sterilization containers fulfil the requirements of DIN EN 868-8 for successful sterilization and drying. They have a perforated lid and are fitted with single-use paper filters.***

**WARNING**

The use of unsuitable sterilization containers results in insufficient steam penetration and even failure of the sterilization. This can also prevent condensate drain-off.

**This produces poor drying results. This can result in unsterile instruments and thus endanger the health of patient and practice team.**

- Closed sterilization containers must be either perforated on at least one location - optimally the bottom - or be equipped with a valve.
- 

**WARNING**

Incorrect stacking of the sterilization containers can result in the dripping condensate being unable to drain off to the chamber floor. This would then saturate the sterilization material directly underneath it.

**This produces poor drying results. This can result in unsterile instruments and thus endanger the health of patient and practice team.**

- Do not cover the perforations when stacking the sterilization containers.
- 

### Soft sterilization packaging

Soft sterilization packaging can be used in both sterilization containers and on trays. Please observe the following when using soft sterilization packaging e.g. MELAfo!

- ▶ Arrange soft sterilization packaging in a perpendicular position and at narrow intervals.
- ▶ Do not place multiple soft sterilization packages flat on top of each other on a tray or in a container.
- ▶ If the seam seal tears during sterilization, this could be caused by the choice of undersized packaging. Should this not be the case, re-pack the instruments and sterilize them again.
- ▶ Should the seam seal rip during sterilization, extend the sealing pulse on the sealing device or make a double seam.

### Multiple wrapping

The sterilizer functions on the fractionated pre-vacuum method. This permits the use of multiple wrapping.



### Mixed loads

Please observe the following when using mixed loads:

- ▶ Always place textiles at the top.
- ▶ Place the sterilization containers at the bottom.
- ▶ Place unwrapped instruments at the bottom.
- ▶ Place transparent sterilization packaging and paper bags at the top - except in combination with textiles. In this case, place them at the bottom.
- ▶ Place heavy loads at the bottom.
- ▶ Transparent sterilization packaging should be loaded on their edges so that the paper side and film side are alternating in contact. If this is not possible, the paper side should face downwards.

| Loading variations*  | Vacuklav 23 B+  |   | Vacuklav 31 B+ |          |
|--|---|---|----------------|----------|
|  | Instruments   | Textiles  | Instruments    | Textiles |
| Max no. per single piece   | 2 kg  | 1.8 kg  | 2 kg           | 1.8 kg   |
| Maximum total  | 5 kg  | 1.8 kg  | 5 kg           | 1.8 kg   |
| Loading variant mounting A   | max. 5 trays, depth 420 mm<br>max. 6 sterilization containers 15 K<br>max. 3 sterilization containers 15M<br>max. 2 sterilization containers 15G<br>max. 6 sterilization containers 17K<br>max. 3 sterilization containers 17M<br>max. 1 sterilization containers 17G<br>max. 3 swab drums 17R<br>max. 1 sterilization containers 23G<br>max. 2 sterilization containers 23M<br>max. 2 swab drums 23R<br>max. 2 sterilization containers 28M<br>max. 1 sterilization containers 28G<br>max. 3 standard tray cassettes | max. 5 trays, depth 290 mm<br>max. 3 sterilization containers 15 K<br><br>max. 3 sterilization containers 17K<br><br>max. 3 swab drums 17R<br><br>max. 2 swab drums 23R<br>max. 2 sterilization containers 28M<br>max. 1 sterilization containers 28G<br>max. 3 standard tray cassettes |                |          |
| *MELAG mount, trays and sterilization containers. See appendix A – accessories |   |   |                |          |

Load patterns designed especially for the dental sector are available from the download area of the MELAG website: [www.melag.de](http://www.melag.de).

## Selecting the program

You can switch between the initial state and the desired program using the program selection switch. Now select the sterilization program according to how and whether the sterilization material is packed. It is also necessary to take into account the temperature resistance of the sterilization material. The following tables show which program is to be selected for which sterilization material.

**Table 1: Overview of the Sterilization programs**

|                           | <b>Universal-Program</b> | <b>Quick-Program B:</b> | <b>Quick-Program S</b> | <b>Gentle-Program</b> | <b>Prion-Program</b> |
|---------------------------|--------------------------|-------------------------|------------------------|-----------------------|----------------------|
| Sterilization temperature | 134 °C                   | 134 °C                  | 134 °C                 | 121 °C                | 134 °C               |
| Sterilization pressure    | 2 bar                    | 2 bar                   | 2 bar                  | 1 bar                 | 2 bar                |
| Sterilization time        | 5.5 min.                 | 5.5 min.                | 3.5 min.               | 20.5 min.             | 20.5 min.            |
| <b>Operating times</b>    |                          |                         |                        |                       |                      |
| Operating time*           | 30min.                   | 30 min.                 | 15 min.                | 45 min.               | 45 min.              |
| Drying                    | 20 min.                  | 10 min.                 | 5 min.                 | 20 min.               | 20 min.              |

\*without drying (full load for Vacuclav 23 B+ and Vacuclav 31 B+: 5 kg) and depending on loading and installation conditions, eg. mains voltage.

**Table 2: Overview of the use of the respective sterilization programs**

| <b>Program</b>           | <b>Packaging/suitability</b>  | <b>Load amount*</b>                              |
|--------------------------|---|--|
| <b>Universal-Program</b> | Single and multiple wrapped mixed loads; hollow-bodied articles, long articles with a low diameter; instruments with narrow lumen (hollow body A) and simple hollow items (hollow body B)   | 5 kg instruments<br>1.8 kg textiles              |
| <b>Quick-Program B</b>   | single wrapped and unwrapped (no textiles)<br>Transfer instruments, long, instruments with narrow lumen (hollow body A) and simple hollow items (hollow body B)   | single wrapped<br>1.5 kg or<br>unwrapped 5 kg    |
| <b>Quick-Program S</b>   | Only unwrapped (no textiles)<br>Simple solid instruments, simple hollow items (hollow body B)   | 5 kg unwrapped instruments                       |
| <b>Gentle-Program</b>    | single and multiple wrapping Larger quantities of textiles, thermo-unstable goods (e.g. plastic, rubber articles); Mixed loads; instruments with narrow lumen (hollow body A) and simple hollow items (hollow body B)                               | textiles 1.8 kg or<br>Thermo-unstable items 5 kg |
| <b>Prion-Program</b>     | Single and multiple wrapped instruments under suspicion of carrying the danger of infection through abnormally altered proteins (e.g. Creutzfeld-Jacob, BSE); instruments with narrow lumen (hollow body A) and simple hollow items (hollow body B) | 5 kg instruments<br>1.8 kg textiles              |

\*valid for Vacuclav 23 B+ and Vacuclav 31 B+

## Selecting automatic pre-heating

Automatic pre-heating is activated as standard. The automatic pre-heating function heats the sterilizer chamber to a program-specific pre-heated temperature before the program start, or holds this temperature between two program runs. This will shorten the cycle times.



### PLEASE NOTE

The sterilizer remains switched on continuously for automatic pre-heating!

To alter this setting proceed as follows:

1. Press the (+) and (-) keys simultaneously to select the set-up menu **Function: Last batch number**.

Navigate in the Function menu using the (+) or (-) keys until the display shows:

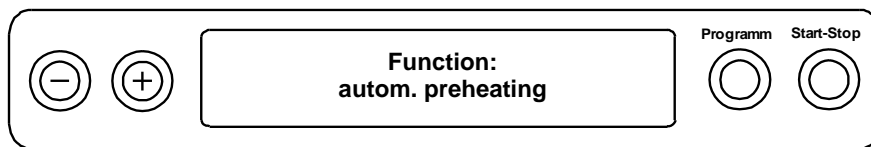

2. Press the (P) key to confirm. The display shows the option currently set, e.g. pre-heating yes.
3. Pressing the (P) key again makes the display switch to **Pre-heating no**. The pre-heating function has been deactivated.
4. In order to end the menu Function: autom. Pre-heating and return to the initial state, press the (S) key twice.



### PLEASE NOTE

MELAG recommends activating the function automatic pre-heating.

## Starting the program



### WARNING

Unsupervised operation of electrical devices, including this sterilizer at the operator's risk. MELAG accepts no liability what so ever for any damage resulting from unsupervised operation.

After selecting a program using the program keys, in addition to the program selected, the display also indicates the temperature and holding time. You will also see whether the program is suitable for wrapped or unwrapped sterilization material.

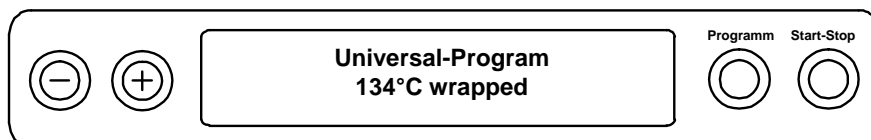

1. Press the (S) key to start the program.  
The sterilizer checks the feed water supply and its conductivity.

**PLEASE NOTE**

If the Quick-Program S has been started, the warning **Warning, only unwrapped instruments** appears on the display.

If a load consists entirely of unwrapped instruments, press the (S) key again to confirm and to start the program.

## Selecting additional drying

The function **additional drying** extends the drying time by 50%. This is suitable for difficult drying tasks.

To do so, proceed as follows:

- ▶ Press the keys (S) and (+) simultaneously upon starting the program. The display shows the menu Function:

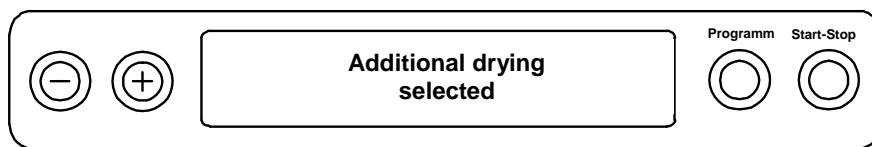

The program run will now begin.

## Program run

After starting the program, you can follow the program run in the display. It shows the chamber temperature and pressure as well as the time until the end of sterilization and the drying time which has passed.

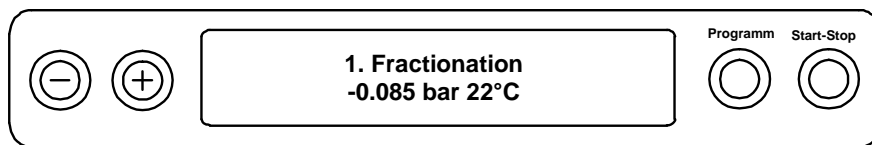

## Sterilization phase is ended

The display enables you to see whether the sterilization phase has already been completed successfully. The time left in the sterilization phase is shown in the display in alternation with the pressure and temperature.

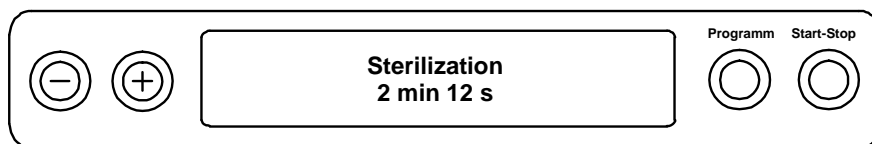

## Drying phase

The regular drying time for the Quick-Program S: 5 minutes. For the Quick-Program B: 10 minutes and for all other programs: 20 minutes. The display will show the corresponding message during the drying phase.

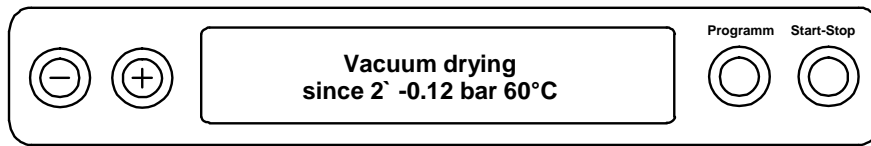

The sterilizer provides excellent drying of the sterilization material. If difficult-to-dry items require better drying, you can undertake the following steps to improve drying:

- ▶ Load the sterilizer properly. e.g. stand the transparent and paper sterilization packaging upright. Observe the contents of the section Loading the sterilizer Loading the sterilizer on page 15. Use a film bracket if necessary.
- ▶ Activate **additional drying**. Observe the contents of the section Selecting additional drying Loading the sterilizer on page 15.

## Program end

The respective program has ended successfully. The display shows the Function menu:

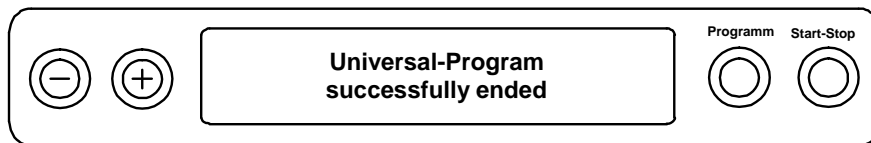

Working in the "Settings" menu under **Function** if immediate output after program end is activated, the log of the completed program will be outputted to the activated output medium after opening the door (see 25, page Chapter 5 - Logging).

## Manual program abort

You can abort a current program in all phases. If you end the program before drying begins, the sterilization material remains **unsterile**. The program will not be classified as successfully completed.



### WARNING

**Aborting a current program by switching off the power switch can result in the egress of hot steam from the sterile filter. This will contaminate the sterile filter.**

- Never abort a program by switching off at the power switch.



### DANGER

The sterilization chamber, door and the sterilized equipment are hot. Moreover, depending on the time of the program abort, opening the door following a program abort can lead to the egress of hot steam.

**Danger of burns from hot steam.**

- Only remove the trays with a tray jack .
- Never touch the sterilized equipment, the sterilization chamber or the door inside with bare hands.

## Manual abort during drying

You can abort the program during the drying phase via the (S) key without the sterilizer registering a fault.

You then need to expect insufficient drying, especially in the case of wrapped sterilized equipment. Sterile storage requires sufficient drying. To ensure this, please allow programs with wrapped sterilized equipment to continue to the end of the drying phase.

Unwrapped instruments sterilized in a Quick-Program dry after being removed from their own warmth.

The drying time completed thus far is indicated on the display during the drying phase. This is performed via a change on the display.

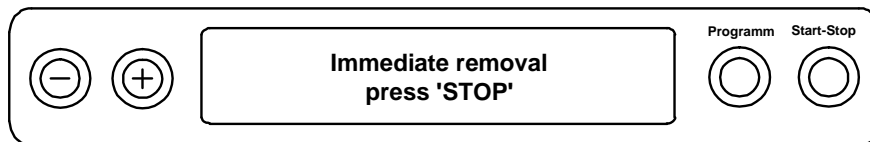

A program abort requires the following steps:

1. Press the (S) key.
2. Confirm the following safety question **Immediate removal `Stop`** by pressing the (S) key repeatedly.

The display confirms the abort with **Drying interrupted**.



### PLEASE NOTE

The safety question will be shown on the display for approx. 5 seconds. If the key is not pressed repeatedly, the program will continue with the usual program run.

After ventilation of the chamber, the display will show: **Universal-Program completed successfully** altering with:

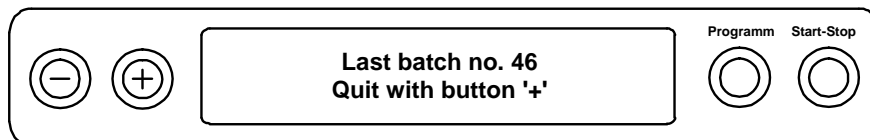

If a printer or other output media is connected to the sterilizer, and the option Immediate output is set to **Yes**, the warning **Drying interrupted** is outputted on the log.

## Manual abort before drying begins

If you end the program before drying begins, the sterilization material remains **unsterile**. The program will not be classified as successfully completed.

A program abort requires the following steps:

1. Press the (S) key.
2. Confirm the following safety question **Abort program?** By pressing the (S) key repeatedly.



### PLEASE NOTE

The safety question will be shown on the display for approx. 5 seconds. If the (S) key is not pressed repeatedly, the program will continue with the usual program run.

Depending on the time of abandonment occurs a pressure relief or venting of the device. A corresponding display text appears on the display.

After the ventilation of the chamber follows the request to quit the Program abort.

The display will alternate between **Abort end** and **Clear with '-'** key.

3. Press the (-) key.

The display alternates between displaying the message **Unlock door with '+'** key and the program previously selected.

4. You can open the door after pressing the (+) key.

The log records the note “program aborted / load not sterilized.”

## Displaying the daily batch counter

The last batch number of the day is shown on the display after every program run.

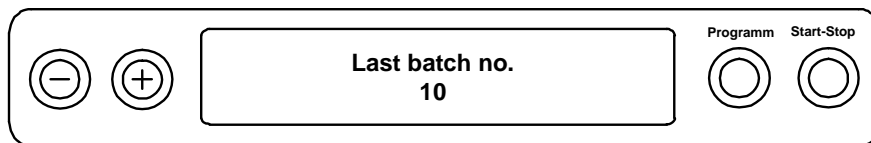

You can also arrange for the batch number to be displayed. To do so:

1. Press the (+) and (-) keys simultaneously to select the set-up menu Function. The display shows the menu **Function: Last batch no.**
2. Press the (P) key to display the current daily batch number.

To return to the basic state, press the (S) key twice.

## Displaying the total batch counter

You can arrange the display of the number of the batches previously recorded.

Press the (+) and (-) keys simultaneously to select the set-up menu Function.

The display shows the **Function menu Last batch no.**

Navigate in the Function menu using the (+) or (-) keys until the display shows:

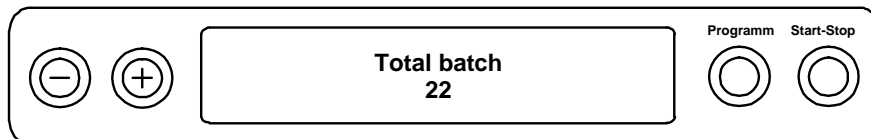

1. Press the (P) key.

The display shows the current total number of batches.

2. To return to the basic state, press the (S) key twice.

## Removing the sterilized equipment



### DANGER

#### Danger of burns

Metal parts and load are hot after the program end. Hot steam egress is possible.

- Comply with the instructions regarding removal of the sterilized equipment.



### DANGER

If packaging is damaged or split during a program run, the instruments may not be sterile.

**This can endanger the health of your patients and practice team.**

- Damaged or split packaging must be repackaged and re-sterilized.

You must observe the following specifications whilst removing the sterilized equipment upon a program end:

- ▶ Never use force to open the door. This could damage the sterilizer and / or result in the emission of hot steam.
- ▶ Use a tray jack to remove the tray.
- ▶ Never touch the sterilized equipment, the chamber or the inside of the door with bare hands. The components are hot.
- ▶ Check the packaging on the sterilized equipment for damage when removing it from the sterilizer.
- ▶ Should the packaging be damaged, re-pack the sterilization material and re-sterilize it.

If you remove the sterilized equipment from the sterilizer directly after the end of the program, it is possible that the instruments can be partially damp.

According to the "Arbeitskreis für Instrumentenaufbereitung" (AKI; Red Broschüre; 10 Edition; S.57): "In practice, residual moisture in the form of a few drops of water capable of evaporating within 15 minutes is tolerated, but actual pools of water are not acceptable."

## Storing sterile equipment

Use only standard-conform packaging for the sterilized equipment. Do not store the sterilized instruments in the treatment room. Observe the provisions of DIN 58953, part 8 and the following criteria when storing sterilized equipment:

Observe the following criteria when selecting the storage location and duration of the sterilized equipment:

- ▶ Protected against dust e.g. in a closed instrument cupboard.
- ▶ Protected from damage to their shiny surfaces.
- ▶ Protected from significant temperature differences.
- ▶ Protected from moisture (e.g. from alcohol, disinfection fluids).
- ▶ The possible length of storage depends on the type of packaging.
- ▶ The maximum storage time is dependent on the packaging and the storage conditions. For standard-conform packaged sterilized equipment (protected from dust) it can amount up to six months.



# Chapter 5 - Logging

---

## Batch documentation

The batch documentation acts as proof of the successful conclusion of the sterilization process and represents an obligatory part of quality control. The sterilizer internal log memory saves such data as the program type, batch and process parameters of the programme completed.

To obtain the batch documentation, you can read out the internal log memory and transfer its data to various output media. This can be performed immediately at the end of every program or at a later point, such as at the end of the day.

## Capacity of the internal log memory

The capacity of the internal log memory is sufficient for 40 logs.

If the internal log memory is full, the oldest log will be overwritten automatically at the beginning of the next program.

If a log printer is connected and the option Immediate output "No" is set (see also page 28, Outputting logs immediately), a safety question will be displayed before the log is overwritten. For further information about connecting the printer, consult the operating manual of the respective device.

## Output media

You are able to output and archive the logs of the completed programs on the following output media. Please observe the user manual of the respective device.

- Log printer MELAprint 42
- MELAflash CF card printer on a CF card
- Connecting the devices to the MELANet Box
- Computer, e.g. with the software MELAtrace/MELAvi<sup>ew</sup>\*

\*From the Device Software 5.11 at least the software MELAvi<sup>ew</sup>/trace is required.

In its state of delivery, an option for log output is not set on the sterilizer.



### NOTICE

For further information of the protocol printer (for example for the duration of for he log printouts) please refer to the respective operating instructions.

---

## Using a computer as an output medium (without a network connection)

The following example shows how to use the computer as an output medium.

You can connect the sterilizer to a computer if the following conditions are fulfilled:

- ✓ *The computer is either fitted with a serial interface or a USB serial adapter is connected.*
- ✓ *The software MELAvi<sup>ew</sup>/MELAtrace is installed on your computer.*



### PLEASE NOTE

The MELANet Box and the software MELAtrace/MELAvi<sup>ew</sup> is required for integration in the practice network.

---

In order to be able to use a computer as an output medium, the computer must be connected to the sterilizer via the serial interface. Connect the computer to the sterilizer as follows:

1. Open the white cover of the serial data- and printer connection from the sterilizer.
2. Turn a coin by a quarter-revolution inserted in the locking slot (Fig. 4/1) on the white cover.
3. Take off the white cover.

4. Press the metal casing somewhat downwards until it engages and fold the interior metal casing to the left (Fig. 4/2).
5. Connect the sterilizer to the RS232 connection with a compatible data connection cable to the computer.

If the computer is continually connected to the sterilizer, the data connection cable of the computer is laid in the cable ducts (Fig. 4/2), the metal casing retracted and the cover is closed again.

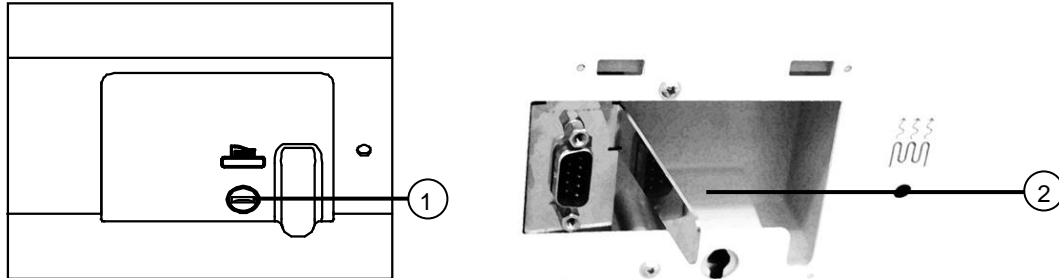

Fig. 4: Connection to the sterilizer

### Reading logs on to the computer

You can use the software MELAview or MELAssoft to read out the logs.

The following sterilizer settings are required to enable registration of the computer on the sterilizer:

1. Switch on the sterilizer.
2. Wait until the display shows the state menu.
3. Press the (+) and (-) keys simultaneously to select the set-up menu Function. The display shows the **Function menu Last batch no.**
4. Navigate in the Function menu using the (+) or (-) keys until the display shows **Function:Log output.**
5. Press the (P) key to select the sub-menu Log issue – output medium.
6. Press the (P) key again. The display shows **Log issue – no outut medium**, if a printer has not been selected.
7. Navigate in the Function menu using the (+) or (-) keys until the display shows:

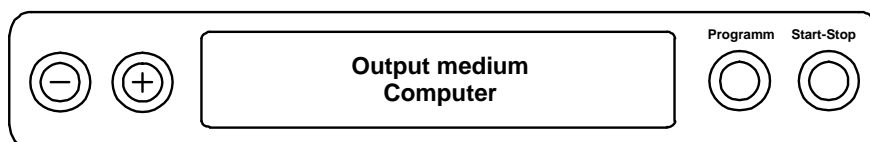

8. Press the (P) key to confirm. The display returns to the menu **Log issue – output medium.**
9. Press the (S) key to return to the set-up menu **Function: log issue.**

After repeated pressing of the (S) key, the display returns to its initial state.

**Opening text logs with a computer**

You can open and print all text logs using a text editor of every operating system or with a word processing or table calculation program.



**NOTICE**

Graphic logs can only be displayed with the documentation software MELAview (as of MELAview 3)/MELAttrace.

To ensure that the operating system at your computer will automatically open the text logs with a text editor, you need to connect the text logs (e.g. PRO, STL, ML etc.) to the text editor. For the meanings of the log endings please see page 31, Reading logs correctly.

The following example of the Windows editor shows how you can link other Windows programs with a particular ending.

1. Double click in Windows Explorer on the log file.
2. Windows 7 displays the adjacent message.

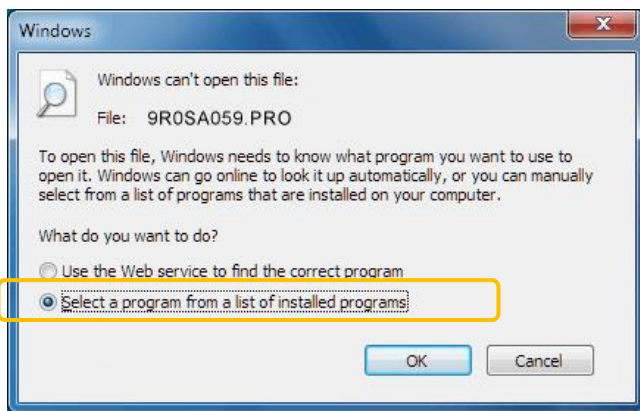

3. Select **Select program from a list of installed programs** and confirm with **OK**.
4. Select the editor from a list of programs in the opening window. Tick the option **Always use the selected program to open this kind of file** and confirm with **OK**.

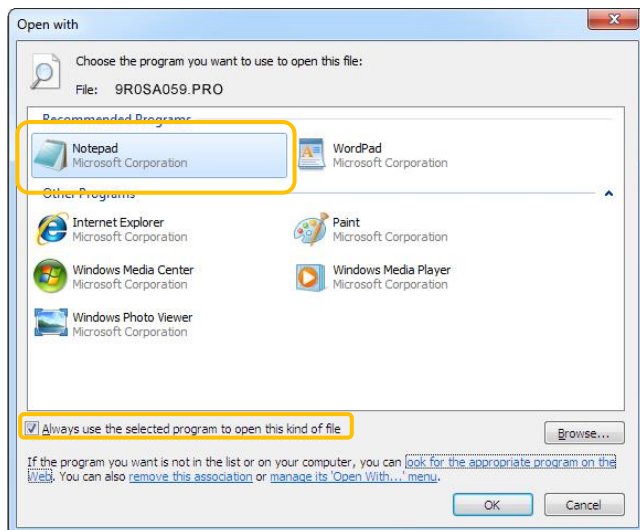

You can then open text logs (e.g. PRO, STL, ML etc.) via a double-click in Windows Editor.

Alternatively, all text logs can be opened with the documentation software MELAview (as of MELAview 3)/MELAttrace.

## Outputting logs immediately and automatically

### Text log

The following requirements must be fulfilled in order to issue logs immediately after the end of a program.

- ✓ Working in the Setup menu **Function: log output** Immediate output is set to **YES**.
- ✓ At least one output medium must be selected (computer, log printer MELAprint 42).
- ✓ The activated output medium must be connected and initialized.

If you want to output the associated text and graphic logs automatically after the end of a program on an output medium, use the function **Immediate output - yes**. This is not set on the sterilizer in its state of delivery.

The options for immediate log issue upon program end are to be set in the following way:

1. Switch on the sterilizer at the power switch.
2. Press the (+) and (-) keys simultaneously to select the set-up menu Function. The display shows the **Function menu Last batch no**.
3. Navigate in the Function menu using the (+) or (-) keys until the display shows: **Function: log issue** and then press the (P) key.
4. Navigate in the Function menu using the (+) or (-) keys until the display shows:

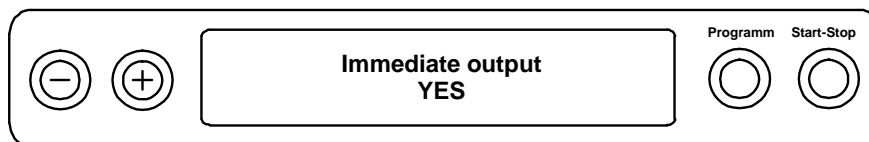

5. Press the (P) key, to switch between Immediate issue **no** / **yes**..

To issue logs immediately, Immediate issue yes must be set.

6. Press the (S) key to save the settings and to leave the menu. The display shows the menu **Function: log issue**.

Pressing the (S) key once again enables you to leave the menu and return to the display initial state.



#### PLEASE NOTE

If automatic logging is unable to issue a log, for example, because the output medium activated is not connected, a warning will appear. MELAG recommends using the immediate log output function.

### Graphic logs (optional)

The following requirements must be fulfilled in order to issue logs immediately after the end of a program.

- ✓ Working in the Setup menu **Function: Log issue** the MELAnet+graphic data is selected as the output medium.
- ✓ The computer or another medium must be connected and initialized.

## Subsequent log output

It is possible to issue logs subsequently and independently of the time of the end of the program. You can choose whether all or only the saved logs (up to 40) are to be printed. Use the output media connected for this task e.g. the log printer.

### Printing selected logs

To print the subsequently selected logs of a particular program proceed as follows:

1. Press the (+) and (-) keys simultaneously to select the set-up menu Function. The display shows the menu **Function: Last batch no.**
2. Navigate in the Function menu using the (+) or (-) keys until the display shows: **Function: log issue** and then press the (P) key.

The menu **Log issue** – output medium is displayed.

3. Navigate in the Function menu using the (+) or (-) keys until the display shows: **Last cycle output No. 40** (as example no. 40).
4. Press the (+) key. The current log number flashes.
5. To issue a log or another cycle, navigate to the desired number using the (+) or (-) keys until you have reached the following number eg. In this case, no. 25.
6. Press the (P) key in order to start the selected program. The display shows the **Function menu**.

After a successful output, the display returns to its previous setting Output last cycle:

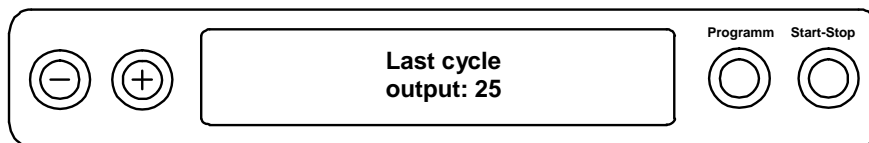

Repeat the last three steps in order to issue further logs.

7. Press the (S) key to leave the sub-menu without outputting the log.
8. Press the (S) key to leave the menu after having outputted the log. The display shows the menu **Function: log issue**.

Repeated pressing of the (S) key enables you to leave the menu entirely and return to the display basic state.

### Printing all saved logs

Proceed as follows to issue all the saved logs subsequently:

1. Press the (+) and (-) keys simultaneously to select the set-up menu Function. The display shows the **Function menu Last batch no.**
2. Navigate in the Function menu using the (+) or (-) keys until the display shows: **log issue** and then press the (P) key.
3. Navigate with the (+) or (-) key until the display shows: **output stored cycles**.
4. Press the (P) key in order to start the selected program. Once the issue has been performed, the display will show:

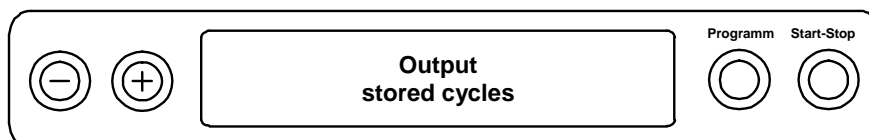

Press the (S) key to leave the sub-menu without issuing the log.

**PLEASE NOTE**

A termination **during** the output on the log printer is only possible by disconnecting the instrument at the mains switch or interrupting the power supply of the printer.

5. Press the (S) key to leave the menu. The display shows the set-up menu  
**Function: log issue.**

Repeated pressing of the (S) key enables you to leave the menu entirely and return to the display basic state.

## Displaying the log memory

If a printer or other output medium is connected and initialized, you can check how many logs have already been saved in the sterilizer log memory.

Proceed as follows:

1. Press the (+) and (-) keys simultaneously to select the set-up menu Function.  
The display shows the **Function menu Last batch no.**
2. Navigate in the Function menu using the (+) or (-) keys until the display shows: **log issue** and then press the (P) key.
3. Navigate in the Function menu using the (+) or (-) keys until the display shows:

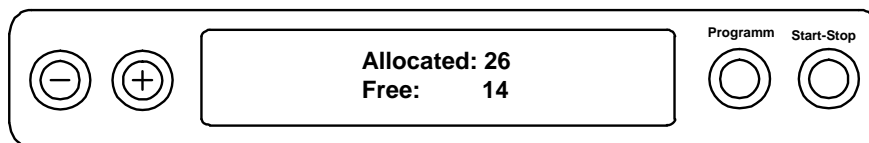

Press the (S) key twice to leave the menu.

## Deleting logs in the internal log memory

Delete the saved logs manually to suppress warning messages, e.g. Log memory full with the option **Immediate issue** set. The following example shows how to delete all the logs saved.

1. Press the (+) and (-) keys simultaneously to select the set-up menu Function.  
The display shows the **Function menu Last batch no.**
2. Navigate in the Function menu using the (+) or (-) keys until the display shows: **log issue** and then press the (P) key.

Navigate in the Function menu using the (+) or (-) keys until the display shows:

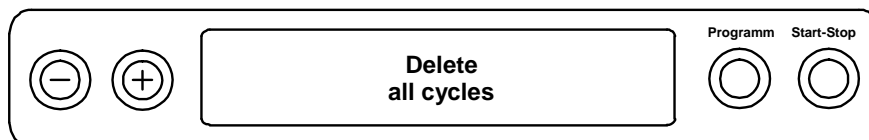

3. Press the (P) key to delete all logs.
4. To cancel the set-up menu without deleting, press the (S) key.
5. Press the (P) key to leave the menu after having deleted it. The display shows the menu  
**Function: log issue.**

Repeated pressing of the (S) key enables you to leave the menu entirely and return to the display basic state.

## Reading logs correctly

| Log type         | File ending | Explanation   |
|------------------|-------------|---|
| text protocol    | .PRO        | Log of a successfully completed program.  |
| Malfunction log  | .STR        | Log of a successfully completed program.  |
| Graphic log      | .GPD        | Program run displayed as a graphic curve.   |
| Standby log      | .STB        | Log for faults in standby.  |
| Demo log         | .DEM        | Protocols of a simulated program.<br>No real sterilization will be performed!                   |
| Demo graphic log | .DEG        | Simulated program run displayed as a graphic curve.<br>No real sterilization will be performed! |

### **Log head**

The head of the program log comprises the general basic information regarding the program run. This includes date, the program selected, the daily batch number and the sterilizer type.

### **Program step values**

The phases of the program run are recorded whilst it runs and the values for steam pressure, temperature and time (related to the program start) are recorded.

### **Summary**

The summary indicates whether the program has been completed successful. The values of the sterilization time recorded, the sterilization temperature and the pressure (including the maximum deviation) are also displayed.

**Table 3: Example for a text log of a successfully completed program**

|  |   |
|--|---|
| <pre> ----- MELAG Vacuklav 31-B -----  Program: Universal-Program         134°C wrapped Date: 24/03/2015 Time: 09:14:19 (Start) Batch no.: 2 SN:      201531-B1541  Pre-heating      127.5 °C AIN6: Conductivity      15 µS/cm  Program step      Pressure  Temperat.  Time                   bar        °C          min Start             0.00      77.0      00:01 1.Fractionating   Evacuation      -0.92      58.2      02:23   Steam inlet      1.00      108.7     04:53 2.Fractionating   Evacuation      -0.82      71.3      06:45   Steam inlet      1.00      109.2     08:33 3.Fractionating   Evacuation      -0.82      66.7      10:35   Steam inlet      0.41      109.3     12:24 Pressure build-up 2.05      134.0     14:40 Steril. Begin     2.05      134.0     14:40 Steril. End       2.19      135.9     20:10 Pressure reduc.   0.14      105.2     20:55 Vacuum-drying   Drying pump      -0.31      94.4      21:03   Drying pressure -0.91      75.1      23:01 +49 -0.91 85.9 25 01 99 +49 -0.92 84.3 27 01 99 +49 -0.93 81.4 29 01 99 +49 -0.93 79.2 31 01 99 +49 -0.93 77.6 33 01 99 +49 -0.94 76.3 35 01 99 +49 -0.94 75.4 37 01 99 +49 -0.94 74.5 39 01 99 +49 -0.94 73.9 41 01 99   Drying end      -0.86      73.8      41:03 +49 -0.29 77.3 41 12 99 End              0.00      79.2      41:24 ----- </pre> | <p>Sterilizer type</p> <p>Program started</p> <p>Current day</p> <p>Time of program start</p> <p>Daily batch number</p> <p>Serial number</p> <p>Pre-heating temperature</p> <p>Feed water Conductivity</p> <p>The phases of the program run are recorded whilst it runs and the values for steam pressure, temperature and time (related to the program start) are recorded.</p> <p>Program stage phases with the associated values for pressure, temperature and time (relative to the program start).</p> <p>Summary</p> <p>The summary indicates whether the program has been completed successfully. The values of the sterilization time recorded, the sterilization temperature and the pressure (including the maximum deviation) are also displayed.</p> <p>Control message</p> <p>Median sterilization temperature with max. deviations</p> <p>Median sterilization pressure with max. deviations</p> <p>Sterilization time maintained</p> <p>Time upon program end</p> <p>Information with total batch counter, factory number and device software number version no.</p> |
| <pre> ----- PROGRAM SUCCESSFULLY COMPLETED -----  Temperature 135.6 +0.4 /-0.3 °C Pressure:    2.17 +0.03/-0.03 bar Sterilization time: 5 min 30 s Time: 09:55:43 (end)  ===== 32 201501541 5.15 5.05 ===== </pre>   |   |



# Chapter 6 – Functional Checks

---

## Automatic functional checks

The electronic parameter control subjects the interaction of the sterilization-relevant parameters pressure, temperature and time to constant automatic monitoring. The sterilizer process evaluation system compares the process parameters during the program with each other and monitors them in terms of their threshold values. The sterilizer monitoring system checks the device components for their functionality and their plausible interaction. Should the parameters exceed pre-set threshold values, the sterilizer emits warning messages or malfunction messages. If necessary, it interrupts the program with appropriate information. When the program has ended successfully, the corresponding message will be issued on the display.

## Manual functional checks

You can follow the program run on the display via the values displayed there. You can also use the logs recorded for every program to determine the success of a program (see Chapter 5 - Logging).

## Batch-related checks

### Helix test body system MELAcontrol / MELAcontrol PRO

The Helix test body system is an indicator and batch control system fulfilling the requirements of DIN EN 867-5. It consists of a test body, the Helix and an indicator strip.

If sterilizing category "critical B" instruments, you should add the MELAcontrol/PRO test body to every sterilization cycle as a batch control.

Regardless of this, you can perform a steam penetration test at any time using MELAcontrol/ MELAcontrol PRO in the Universal-Program.

Intended use of the Helix test body can result in the colouration of the plastic surface. This colouration exercises no influence on the functionality of the Helix test body.

## Vacuum test

The test serves to determine leaks in the sterilizer. The leakage rate is determined in the process.

Conduct a vacuum test in the following situations:

- Once weekly in routine operations.
- During commissioning.
- Following longer operating pauses.
- Following a malfunction (e.g. in the vacuum system).

Perform the vacuum test with the sterilizer in a cold and dry state as follows:

1. Switch on the device at the mains switch. The display switches to its initial state.
2. Press the (P) key until the display shows **Vakuum-test**.
3. Close the door.
4. Press the (S) key to start the vacuum-program.

The evacuation pressure and the equilibration time or measuring times are shown on the display. The chamber will be ventilated after the end of the measuring time (corresponding message on the display). Then the message will be shown on the display with an indication of the leakage rate. Should the leakage rate be too high e.g. over 1.3 mbar, a corresponding message will be issued on the display. Following a successful test program, the current daily batch number is displayed, alternating with the message **Clear with '+'**. You can open the door after pressing the (+) key.

**PLEASE NOTE**

If a log printer or another output medium is connected and the setting immediate output is set, a log printout will be issued at the same time.

## Bowie & Dick test

The Bowie & Dick test serves as proof of the steam penetration of porous materials such as textiles.

Specialist stockists provide various test systems for the Bowie & Dick test . Perform the test according to the test -system manufacturer information.

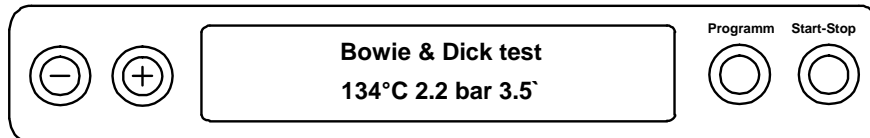

How to start the Bowie & Dick test program:

1. Switch on the device at the power switch.
2. Select the Bowie & Dick test using the (P) key.
3. Press the (S) key to start the Bowie & Dick test .

Following a successful test program, the current daily batch number is displayed, alternating with the message Clear with '+'. You can open the door after pressing the (+) key.

**PLEASE NOTE**

If a log printer or another output medium is connected and the setting immediate output is set, a log printout will be issued at the same time.

**PLEASE NOTE**

Treatment indicator strips often exhibit differing intensities in the colour change indicating a different length of storage of the manufacturer batches or other influences. Of crucial importance for evaluating the Bowie & Dick test is not the strength of contrast in the colour change on the test sheet, but its even nature.

If the treatment strips/treatment indicator sheet indicates an equal distribution of colour change, the air-removal of the sterilization chamber is without fault.

If the treatment indicator strips or the treatment indicator sheets are uncoloured or exhibit less colour in the centre of the star in comparison to the end, air-removal was insufficient. In such a case, please consult the stockist customer services / MELAG customer services.

## Checking the quality of the feed water

You can access the water quality on the display at any time during a current program when the sterilizer is switched on.

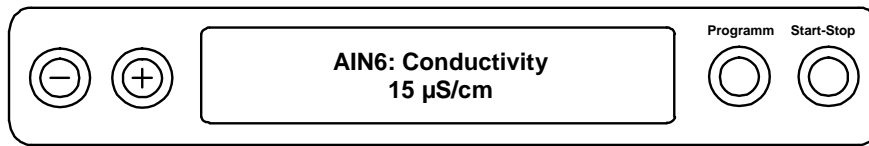

To do so, hold the (-) key depressed until the display shows the conductivity. The conductivity is displayed in µS/cm.

As soon as you have released the (-) key, the display returns to its previous state (e.g. initial state).

## Check pre-heating temperature of the chamber

If pre-heating is activated, the sterilizer will warm the cold chamber or will maintain the temperature between two sterilization runs. This reduces program times and reduces the accretion of condensation, thus improving drying results.

After having pressed the (-) key shortly twice, hold depressed the second time. Instead of displaying the conductivity, you will see the chamber pre-heating temperature.

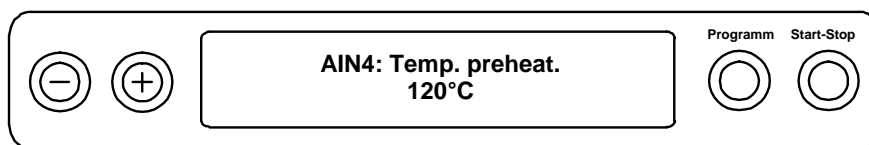

# Chapter 7 - Maintenance

---

## Checks and cleaning

### Door seal, chamber, chamber sealing face, mount, trays

Check the chamber, including the door seal and chamber sealing face and the load mount once a week for impurities, deposits or damage. If you find any impurities, remove the trays or cartridges from the chamber from the front. Clean the soiled components.

When cleaning the chamber, load brackets and chamber seal face, please observe the following:

- ▶ Switch off the sterilizer before cleaning and remove the plug from the socket.
- ▶ Ensure that the chamber is not hot.
- ▶ Use a soft, non-fuzzing cloth.
- ▶ Use a chlorine- and vinegar-free cleaning fluid.
- ▶ First soak the cloth with the cleaning alcohol or spirit and attempt to remove the impurities with this method.
- ▶ Only if the chamber, mount or chamber seal face has persistent soiling should you use a mild stainless steel cleaning agent, with a pH value between 5 and 8.
- ▶ To clean the door seal, use a neutral liquid cleaning agent.
- ▶ You should not allow cleaning fluid to enter the piping coming from the sterilizer chamber.
- ▶ Do not use any hard objects such as metal saucepan cleaner or a steel brush.



#### WARNING

**Inappropriately performed cleaning can lead to the scratching of and damage of surfaces and the development of leaks in sealing surfaces. This creates conditions favourable to dirt deposits and corrosion in the sterilization chamber.**

- Comply with all information regarding cleaning of the part affected.
- 

### Internal storage tank



#### PLEASE NOTE

Ensure that all soiling is removed from the chamber using a cloth. Do not leave any residue. If soiling particles are loosened but not removed, they can enter the dirt particle filter (integrated in the drainage hose) when the waste water tank is emptied.

**Failure to comply could impair the life-expectancy of the dirt particle filter and necessitate short-term replacement.**

---

Should you decide upon manual supply of the feed water via the internal storage tank, check the feed water side (the right-hand side) for soiling whilst refilling. If necessary, use a cloth and fresh feed water to clean the storage tank before filling.

Clean the waste water side (left chamber) of the internal storage tank every two weeks.

Empty both chambers of the storage tank as follows:

1. Connect the effluent hose on a quick coupling (left: waste water tank, right: feed water tank) until this snaps in.
2. Discharge the water into a container with min. volume of 5 litres.
3. Repeat the procedure for the other chamber if necessary.

Press the grey unlocking key on the quick coupling to remove the effluent hose. The hose will free itself from the coupling on its own.

**WARNING**

**When removing the quick coupling, please observe:**

- To empty the reservoir, stand in front of the connection to one side.
- Hold the hose with one hand whilst pressing the grey unlocking key on the quick coupling with the other. This dampens the spring force of the seal.

**Failure to observe these provisions can result in injury.**

---

## Avoiding staining

Only after cleaning instruments properly prior to sterilization is it possible to avoid residue from the load or the instrument treatment from being released during sterilization. Loosened dirt residue (e.g. from disinfectants) can clog the sterilizer filter, nozzles and valves and deposit themselves on the instruments and chamber as deposits and stains (see page 14, Preparing the sterilization load).

All steam-conducting parts of the sterilizer consist of non-rusting material. This rules out the possibility of stain or rust development being caused by the sterilizer. The development of rust is always extraneous rust.

Incorrect instrument treatment can result in the accretion of rust even on stainless steel instruments of leading manufacturers. Often, an instrument which drops rust can suffice to cause the development of rust on another instrument or in the sterilizer.

Remove foreign rust from the instruments using chlorine-free stainless steel cleaning fluid (see page 36, cleaning) or send the damaged instrument to the manufacturer.

## Replacing the door seal

The door seal may not be greased or oiled. It should be kept clean and dry. If the door seal becomes worn and loses form, it must be replaced. Otherwise, this could result in leaks which will enable steam egress, or too high a leakage rate in the vacuum test.

Proceed as follows to replace the door seal:

1. Open the sterilizer door and remove the old door seal. The door seal is now inserted in the groove of the round blank (page 9, Fig. 3/5). Insert the new door seal in the groove in such a way that the **wider seal face points towards the chamber side**.

**IMPORTANT!**

Ensure you observe the different breadths of the seal faces. The door can only be shut correctly and the chamber sealed, if the door seal sits correctly in the groove.

---

## Aligning the door seal sealing lip

Long periods of storage with the door closed can result in the sealing lips of the door seal becoming stuck. Align the sealing lips to prevent leaks.

Proceed as follows:

1. Remove the door seal.



2. Press your thumb between the two sealing lips and separate the sealing lips once around with your thumb.



### PLEASE NOTICE

Note the differences in the widths of the sealing surfaces when inserting the door seal. The door can only be shut correctly and the chamber sealed, if the door seal sits correctly in the groove.

3. Insert the door seal into the groove. The wide sealing surface points towards the chamber.



## Replacing or sterilizing the sterile filter

The sterile filter must be replaced regularly within the scope of the maintenance. Given the incidence of a malfunction and the malfunction message "Malfunction 32: power outage/sterilize sterile filter, the sterile filter should either be replaced or sterilized.



### WARNING

Only ever operate the steam sterilizer with a sterile filter inserted.

### Changing the sterile filter

1. Remove the sterile filter by turning and pulling it from the holding sockets simultaneously.

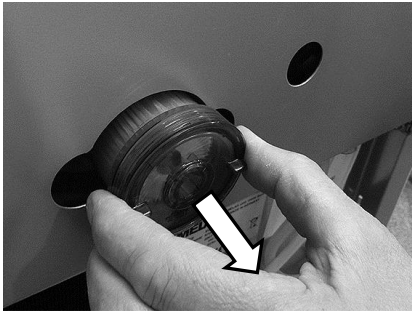

2. Replace the sterile filter or sterilize the current sterile filter as described under the point "Sterilizing the sterile filter".
3. Exert a little pressure on the sterile filter and turn to insert it into the holding sockets.

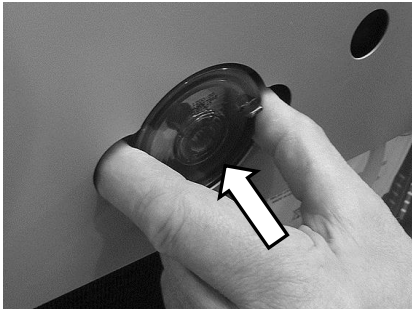

### Sterilizing the sterile filter

1. Remove the sterile filter by turning and pulling it from the holding sockets simultaneously.
2. Slide a perforated tray into the steam sterilizer and place the sterile filter vertically on the tray. Ensure that the sterile filter does not fall over, otherwise the condensate will not be able to drain away correctly.



3. Start the Gentle-Program.
4. Remove the sterile filter from the device after the program end and allow it to cool for min. 15 minutes.
5. Exert a little pressure on the sterile filter and turn to insert it into the holding sockets.

## Cleaning the filter in the chamber

1. Unscrew and remove the filter (anti-clockwise) from the opening to check and clean it.
2. Rinse the filter with water to clean.
3. Screw in the filter into the opening in a clockwise direction.

Unscrew the chamber filter (fig. 6/c) using the chamber filter wrench included in the scope of delivery.

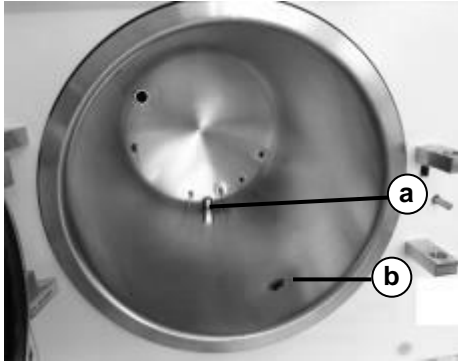

Fig. 5 view of the interior

- (a) Condensate reflux filter .
- (b) Chamber filter.
- (c) Wrench for the chamber filter.

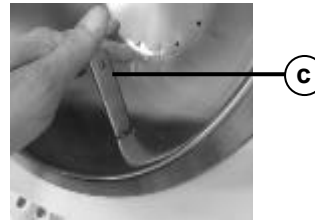

Fig. 6 unscrew the filter of the chamber

## Maintenance



### WARNING

**Continuing operation despite maintenance messages can result in malfunctions in the sterilizer.**

- Maintenance should only be performed by trained customer services technicians, or stockist technicians. Consult your stockist or the nearest MELAG customer services point.
- Maintain the specified servicing intervals.

Regular maintenance is vital to ensure reliable operation and value retention of the sterilizer. All function and safety-relevant components and electrical units are checked during maintenance and replaced where necessary. Maintenance should be performed after every 1000 program cycles or 2 years. The sterilizer will issue a maintenance message at the relevant time.



### A NOTE CONCERNING THE ORDINANCE OF INDUSTRIAL SAFETY & HEALTH

According to BetrSichV §15, the operators of pressure devices such as sterilizers are obliged to arrange for regular checks of their devices for their correct state. Our homepage contains guidelines to download. These contain recommendations as to the intervals at which you should check each component.



# Chapter 8 – Operating Pauses

## Sterilization times

Pause times between individual programs are not necessary. After the end or abort of the drying time and removal of the sterilized equipment, you can load the sterilizer again and start the sterilizer afresh.

## Operating pauses

Depending on the duration of the operating pauses, the following measures must be maintained:

| Duration of the operating pause                  | Measure   |
|--|---|
| between two sterilizations, longer then one hour | <ul style="list-style-type: none"> <li>▪ Switch off sterilizer (saves energy).</li> </ul>   |
| overnight or on the weekend                      | <ul style="list-style-type: none"> <li>▪ Switch off sterilizer.</li> <li>▪ Leave the door ajar to prevent a sticking of the door seal.</li> <li>▪ Close, if available, the water feed of the water treatment unit.</li> </ul> |
| Longer than two weeks                            | <ul style="list-style-type: none"> <li>▪ Perform vacuum test.</li> <li>▪ Then perform an empty sterilization with the Quick Program (see page 33, <b>Chapter 6 – Functional Checks</b>).</li> </ul>                           |

After pauses, perform the checks described in chapter 6 – functional checks depending on the length of pause.

## Decommissioning

When decommissioning the sterilizer for a long pause (e.g. due to holiday or planned transport), proceed as follows:

1. Switch off the sterilizer at the power switch.
2. Remove the plug from the socket.
3. Empty both chambers of the storage tank.
4. Close the water inflow if you are using a water treatment unit.



### PLEASE NOTE

Please comply with the technical manual. This contains all building-side requirements.

## Recommissioning after relocation

When recommissioning after a move, proceed as with the first commissioning (see page 12, Chapter 3 – First commissioning).

# Chapter 9 – Description of function

## The sterilization procedure

The sterilizer sterilizes on the basis of the fractionated vacuum procedure. This guarantees the complete and effective wetting / penetration of the sterilization material with saturated steam. This option enables the sterilization of loads common to a doctor's practice or clinic.

The sterilizer uses a separate steam generator to generate the sterilization steam. Steam is generated upon program start and led into the sterilization chamber. This establishes a pre-defined pressure and temperature.

The sterilization material is dried using a vacuum (vacuum drying). This brings the best drying results even when using wrapped sterilization material.

## Type of the feed water supply

The sterilizer works with a feed water one-way system. This means that it uses fresh feed water for each sterilization procedure. The quality of the feed water is subject to permanent monitoring via an integrated conductivity sensor.

## Internal process monitoring

The sterilizer electronics has an integrated process evaluation system. It compares the process parameters (such as temperature, time and pressure) during a program run. This means that the door cannot be opened during excess pressure in the sterilization chamber. The sterilization chamber is protected against overheating and the total operating time of a program is optimized in dependence on the load.

It monitors the parameters in terms of their threshold values during control and regulation and guarantees safe and successful sterilization. If one or more parameters depart from the threshold values determined, the sterilizer issues warning or malfunction messages and if necessary, aborts the program.

## Program

### Program type

#### *Regular sterilization program*

| Program phase          | Description  |
|------------------------|--|
| 1. Air-removal phase   | During the air-removal phase, air is removed repeatedly until a program-independent pressure has been reached. This is performed in alternation with steam injection until a low over-pressure has been reached. Depending on the program selected and the current chamber temperature upon program start, further fractionations can also follow. |
| 2. Heating phase       | The heating phase follows the ventilation phase. The continued steam admittance into the chamber leads to an increase in pressure and temperature which continues until the sterilization parameters have been reached.  |
| 3. Sterilization phase | After the sterilization parameters pressure and temperature have been met, the sterilization phase begins.   |
| 4. Drying phase        | The drying phase begins after the pressure release. Chamber ventilation and simultaneous pressure equalization is performed at the end of drying.  |
| 5. Ventilation         | Once the program has come to an end, the chamber pressure is adapted to the ambient pressure. The corresponding display message "ventilation" is displayed.  |

**Vacuum test**

| Program phase         | Description  |
|-----------------------|--|
| 1. Evacuation         | The chamber will be evacuated until the pressure for the vacuum test has been reached.   |
| 2. Equilibration time | An equilibration time of five minutes will follow.   |
| 3. Measuring time     | The measurement time amounts to ten minutes. The pressure increase within the chamber is measured within the measurement time. The evacuation pressure and the equilibration time or measuring times are shown on the display.                             |
| 3. Ventilation        | The chamber is ventilated after the end of the measuring time. Then the message will be shown on the display with an indication of the leakage rate. Should the leakage rate be too high (i.e. over 1.3 mbar), this will also be indicated on the display. |
| 4. Test end           | Following a successful test program, the current daily batch number is displayed, alternating with the message Clear with '+'. You can open the door after pressing the (+) key.   |

**Overview of the Sterilization programs**

The results in this table show which inspections were performed on the sterilizer. Fields marked show compliance with all applicable sections of the standard DIN EN 13060.

| Type tests   | Universal-Program | Quick-Program B | Quick-Program S | Gentle-Program | Prion-Program |
|--|-------------------|-----------------|-----------------|----------------|---------------|
| Program type in accordance with DIN EN 13060       | Type B            | Type B          | Type S          | Type B         | Type B        |
| Dynamic pressure test of the sterilization chamber | X                 | X               | X               | X              | X             |
| Air leakage  | X                 | X               | X               | X              | X             |
| Empty chamber test                                 | X                 | X               | X               | X              | X             |
| Solid load   | X                 | X               | X               | X              | X             |
| Porous partial load                                | X                 | --              | --              | X              | X             |
| Porous partial load                                | X                 | --              | --              | X              | X             |
| simple hollow items(hollow body B)                 | --                | --              | X               | --             | --            |
| Instruments with narrow lumen (hollow body A)      | X                 | X               | --              | X              | X             |
| Single wrapping                                    | X                 | X               | --              | X              | X             |
| Mltiple wrapping                                   | X                 |                 | --              | X              | X             |
| Drying massive load                                | X                 | X               | X               | X              | X             |
| Drying, porous load                                | X                 | --              | --              | X              | X             |

## Overview of programs

### MAIN menu

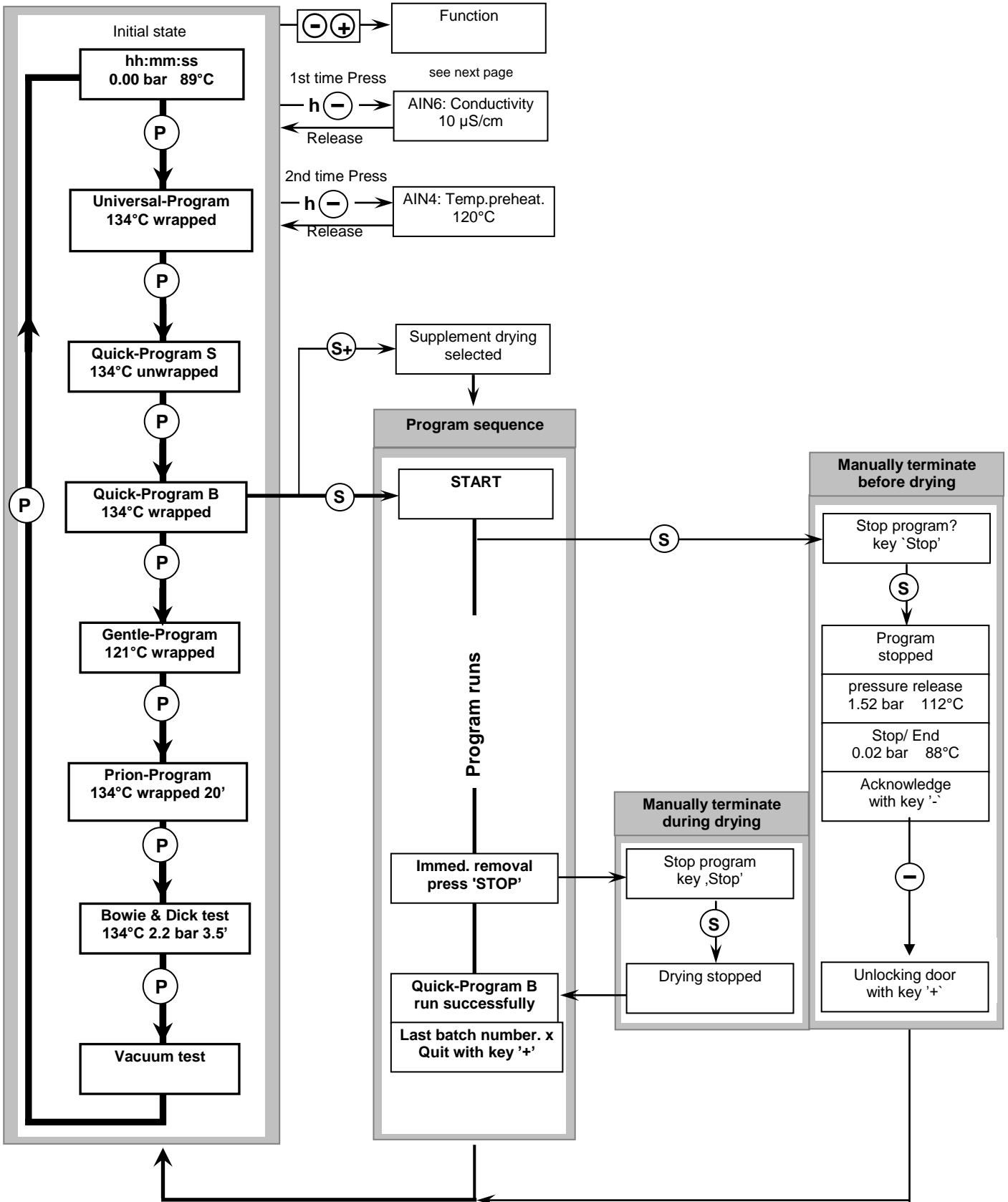

⊕⊕ PRESS KEY (S) and (+) simultaneously

Ⓢ KEY „Start/Stop“ and terminate a program

Ⓟ KEY „Program“: "Enter/Confirm/Input

⊕⊖ Press (+) and (-) simultaneously to select the SETUP menu

h ⊖ Select by keep pressing the key (-)

⊕ Unlocking door with key (+)

Program overview: SETUP menu: Function

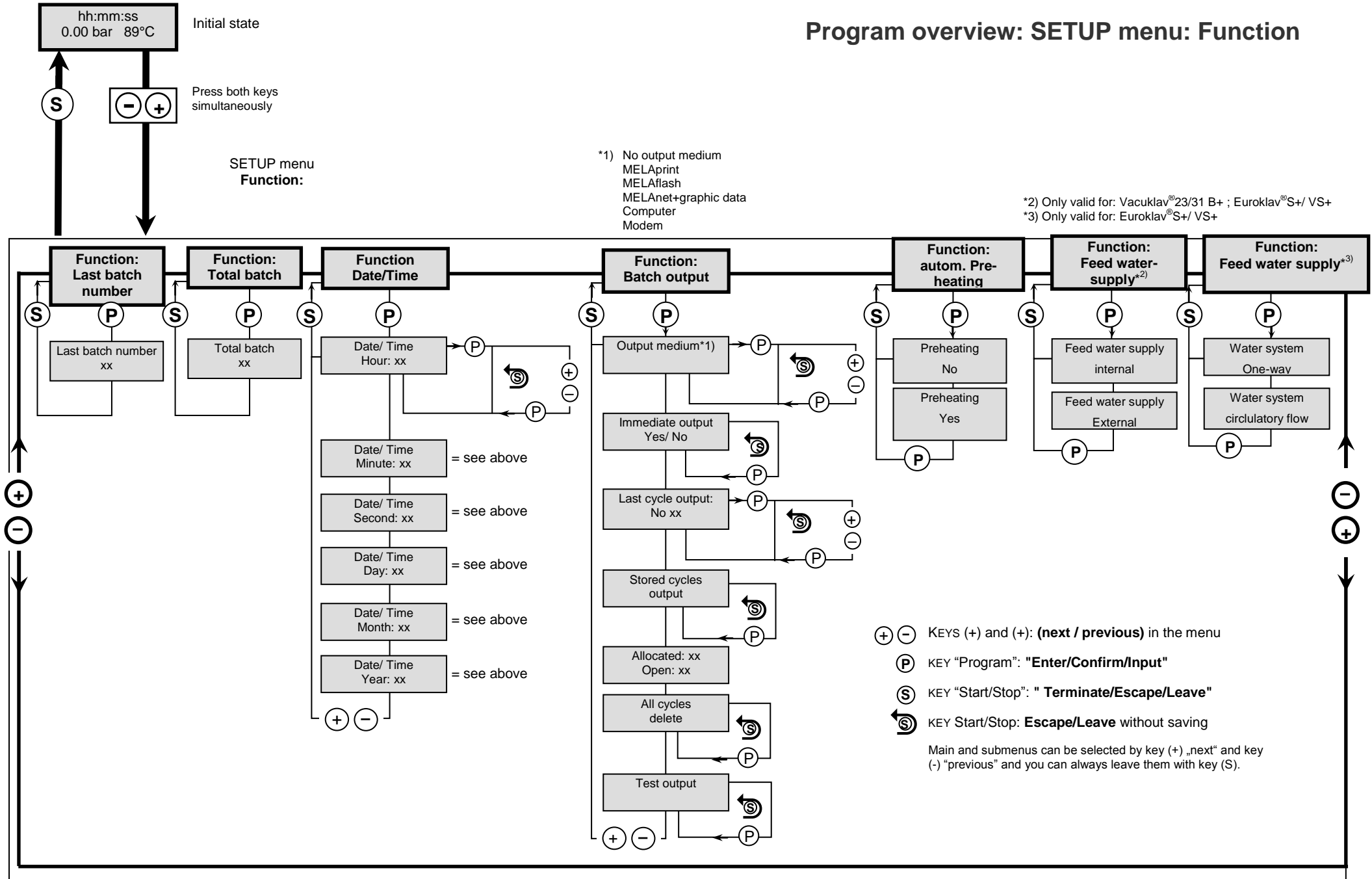

## Chapter 10 – Malfunctions

---

### Warnings

Warning messages are not malfunction messages. They help to ensure malfunction-free operation and to recognize undesirable situations. Observe these warnings early in order to avoid malfunctions.

### Malfunction message

Warnings and malfunction messages are issued on the display with an event number. This number serves identification purposes.

Malfunction messages are issued when it is not possible to ensure safe operation or safety of sterilization. These can appear on the display shortly after switching on the sterilizer or while a program is running.

If a malfunction occurs during a program run, the program will be aborted.



#### **DANGER**

Aborting a program before the drying phase means that the load is unsterile.

**This endangers the health of your patients and practice team.**

- If necessary, repack the load and repeat the sterilization for the sterilization material affected.
- 

### Before you call customer service

Ensure that you have complied with all instructions relating to a warning or malfunction message issued by the display of the sterilizer. The following table contains a summary of the most important events. The events contain possible causes and the corresponding operator information.

Should you be unable to find the relevant event, or your efforts do not redress the problem, you can contact your nearest stockist or authorized MELAG customer service provider. To enable us to give the best possible service, please have your sterilizer serial number and a detailed description of the fault contained in the malfunction message to hand.

**General event**

| Incident                        | Possible cause  | What you can do:   |
|---------------------------------|---|--|
| Empty display                   | No current<br>(2 points.)   | <p>Check the power plug for its correct position in the socket.</p> <p>Check the electricity supply on the socket</p> <p>Change the device fuses on the lower sterilizer front if necessary (see page 9/10 ). To do so, follow the instructions in the technical manual under device fuse.</p>   |
| You cannot open the door        | The door seal sticks to the seal face.  | Switch on the sterilizer, confirm with the (+) key and pull strongly on the door.  |
| Too high feed water consumption | <p>The sterilizer is loaded incorrectly.</p> <p>The sterilizer is not set-up correctly.</p> <p>Condensate reflux is prevented.</p>            | <p>Comply with the prescribed load quantity. (Page 15, Loading the sterilizer).</p> <p>Check for the correct set-up of the sterilizer. If necessary, increase the slope of the device feet by unscrewing them by max. two revolutions.</p> <p>Remove any instruments, filter paper or other objects which have fallen onto the chamber floor.</p>  |
| Bad drying results              | <p>The sterilizer is loaded incorrectly.</p> <p>The sterilizer is not set-up correctly.</p> <p>Condensate reflux is prevented or blocked.</p> | <p>Comply with the prescribed load quantity (see page15, loading the sterilizer). The textiles may not have direct contact with the chamber wall and floor.</p> <p>Check for the correct set-up of the sterilizer. If necessary, increase the slope of the device feet by unscrewing them by max. two revolutions.</p> <p>Remove any instruments, filter paper or other objects which have fallen onto the chamber floor.</p> <p>Check the chamber filter and condensate reflux filter for blockage.</p> <p>Activate the pre-heating (see page 19,Select automatic pre-heating).</p> <p>Activate additional drying (see page 20, additional drying).</p> |

## Warnings

| Warning  | Possible cause  | What you can do  |
|--|---|--|
| Warning, door open and Start not possible                      | Door contact is not closed upon start.  | Press down the slide locking grip downwards to its fullest extent.   |
| Warning no feed water / refill feed water - start not possible | Only with feed water supply from an internal storage tank:<br>Insufficient feed water in the internal storage tank.   | Check the fill level of the feed water in the internal storage tank; if necessary, fill the feed water up to the MAX mark.   |
| Attention no feed water/ check the feed water inflow           | The warning will be displayed after a program start. The installed flow monitor does not close.   | <p><b>Feed water via the internal storage tank</b></p> <p>Should this message appear repeatedly, arrange for an inspection by MELAG customer service.</p> <p><b>Feed water supply from the MELdem 40</b></p> <p>Check the water treatment unit; open the inflow to the unit if necessary.</p> <p>Should this message appear repeatedly, arrange for an inspection by MELAG customer service.</p> <p><b>Feed water supply from the MELdem 47</b></p> <p>Check the water treatment unit; open the inflow to the unit if necessary. Should this message be repeatedly issued with an empty pressure accumulator after c. 1 hour new start, arrange for an inspection of the water treatment unit by MELAG customer service.</p> <p><b>Please note!</b> This message can be issued following commissioning/recommissioning, as the pipe system is still empty. Repeat the start.</p> |
| Poor feed water/replace the cartridge or module                | <p>Feed water conductivity too high.</p> <p>Conductivity 40 µS/cm.</p> <p>Mixed-bed resin exhausted.</p> <p>Mixed-bed resin in subsequent ion exchanger (3. cartridge) exhausted.</p> | <p><b>Start through repeated depressing of the (S) key still possible</b></p> <p><b>Feed water supply from:</b></p> <p><b>MELAdem 40:</b></p> <p>Change the mixed-bed resin, see operating manual for the water treatment unit MELAdem 40.</p> <p><b>MELAdem 47:</b></p> <p>Change the mixed-bed resin, see operating manual for the water treatment unit MELAdem 47 and check the treatment unit.</p> <p>On repeated occurrence, arrange for maintenance to be performed by MELAG customer service / the customer service of your stockist. The pre-filter and active coal filter may need to be changed.</p>   |



| Warning   | Possible cause   | What you can do   |
|---|--|---|
| Poor feed water/replace the cartridge or module         | Mixed-bed resin in reverse-osmosis unit exhausted.   | <p><b>Other water treatment unit:</b></p> <p>Change the module / resin cartridge according to the manufacturer's operating manual.</p> <p>Upon repeated occurrence.</p> <p><b>PLEASE NOTE!</b> Perform a program start after finishing the work outlined above. This warning can be issued upon the initial start after maintenance of the water treatment unit, as the inflow hose has not rinsed the measurement cell fully with fresh water.</p> |
| Insufficient quality of feed water / start not possible | <p>Feed water conductivity too high.</p> <p>Conductivity 65 µS/cm.</p>   | <p><b>Start no longer possible:</b></p> <p>See warning message "Poor feed water/replace the cartridge or module."</p>   |
| Please wait<br>The chamber is warming                   | This display appears during the program start phase. The sterilizer has not yet reached the starting temperature.  | The sterilizer starts automatically after the starting temperature has been reached.  |
| Warning / change sterile filter                         | <p>Min./Max. pressure is exceeded / undercut during air-drying.</p> <p>Sterile filter soiled or torn.</p>  | <p>Replace the sterile filter.</p> <p><b>PLEASE NOTE</b> The message comes at the end of the program and in the last line of the log print-out.</p>   |
| Output medium is not ready                              | <p>The sterilizer is operating without an output medium, but one has been registered.</p> <p>The output medium has not been connected properly</p> <p>The electricity supply to the printer has been interrupted.</p> <p>The printer is "offline."</p> | <p>In the menu log issue, set the option no output medium.</p> <p>Check the correct connection of the data cable to the sterilizer and the output medium.</p> <p>Check the electricity supply. The red LED "P" on the log printer MELAprint 42 must be illuminated.</p> <p>Set the printer to "online" (press the "SEL" key on the MELAprint 42, the "SEL" LED must illuminate green).</p>  |

| Warning                                     | Possible cause  | What you can do  |
|---|---|--|
| Log memory full                             | <p>The device-internal log memory is full (max. 40 logs possible).</p> <p>An output medium has been registered and the option <b>Immediate issue – no</b> has been set in the Log issue menu.</p> | <p>The message is displayed upon program start.</p> <p>Repeated pressing of the (S) key removes the message and the program starts. The oldest log will be deleted in the process.</p> <p>Set sterilizer to <b>Immediate output</b> yes (see page 28,</p> <p>Outputting logs immediately and automatically).</p> <p>Delete the printer memory (see page, deleting the printer memory (see page 30, Deleting logs in the internal log memory</p> <p>Delete the logs in the internal log memory. Deleting logs in the internal log memory, see page 29), If necessary, output all the saved logs beforehand (see page 29, Printing all saved logs Printing all saved logs</p> <p>Unregister the output medium in the <b>Log issue</b> menu and set the option <b>No output medium</b>.</p> |
| Carry out maintenance                       | <p>The maintenance message has been activated and the device has reached the pre-set number of charges.</p>   | <p>This message is displayed upon every program start.</p> <p>Repeated pressing of the (S) key removes the message and the program starts.</p> <p>Press the (S) key twice.</p> <p>Arrange for maintenance to be performed by the MELAG customer services / your specialist stockist customer services</p> <p><b>PLEASE NOTE</b> The maintenance counter is to be reset by customer services</p>  |
| Test not successful<br>Rate of leakage: 3.2 | <p>The leakage rate determined during the vacuum test lies over the maximum permissible value of 1.3 mbar.</p> <p>Door seal, chamber flange soiled.</p> <p>Door seal set incorrectly.</p>         | <p>Check that the door seal and chamber flange are clean and clean if necessary.</p> <p>Control the door seal for wear, change if necessary (see page 37 Replacing the door seal).</p> <p>Repeat the vacuum test with an entirely cold device.</p> <p>Check the door seal for its correct position.</p> <p>Repeat the vacuum test with an entirely cold device.</p>  |
| Warning Battery empty                       | <p>Monitoring of the internal battery voltage has returned too low a value.</p>   | <p>The battery is to be changed by MELAG customer services / your specialist stockist customer services.</p>   |

**Fault messages**

| Malfunction message                  | Possible cause  | What you can do  |
|--------------------------------------|---|--|
| Fault 1: Vacuum system               | <p>Door seal, seal face on the chamber soiled or defective.</p> <p>Door seal set incorrectly.</p> <p>The chamber filter is blocked.</p> | <p>Check the door seal and seal face on the chamber for soiling and clean.</p> <p>Check the door seal for wear, change if necessary (see page 37 Replacing the door seal).</p> <p>Check the door seal for its correct position.</p> <p>Check that the sterilizer is set up correctly.</p> <p>Check the sterilizer for instruments, filter papers or other objects with have fallen onto the chamber bottom.</p> <p>Check the chamber filter for soiling and clean if necessary. To do so, use the chamber filter wrench (see page 37 Replacing the door seal).</p> |
| Fault 2: Steam generator             | <p>Sterilizer is overloaded.</p> <p>Reduced heat production, as the mains voltage is too low.</p>                                       | <p>Ensure that the sterilizer is loaded correctly (see page 15, Loading the sterilizer).</p> <p>Check the on-site electrical connection. Try operating the device on a different electrical circuit.</p> <p>Upon repeated occurrence, inform your stockist.</p>  |
| Fault 4: Pressure release            | <p>Pressure release filter is soiled.</p>   | <p>Check whether the pressure-release filter is clogged (in chamber bottom in the rear area). Unscrew the filter beforehand.</p> <p>Upon repeated occurrence, inform your stockist.</p>  |
| Fault 8:                             | <p>The maximum difference between the program run time and the internal computer clock has been exceeded.</p>                           | <p>Upon repeated occurrence, inform your stockist.</p>   |
| Fault 9: Door open                   | <p>The locking sliding handle was pushed upwards during a running program.</p>  | <p>Push the sliding closure grip downwards until the stop. Correct display: <b>Door closed</b>.</p> <p>Upon repeated occurrence, inform your stockist.</p>   |
| Fault 10: Overheated Steam generator | <p>Overheat Steam generator.</p>  | <p>This malfunction message can be generated following a program abort and direct re-start. Repeat after a two minute pause.</p> <p>Upon repeated occurrence, inform your stockist.</p>  |
| Fault 12: Door lock                  | <p>Locking pin of the door is stiff.</p>  | <p>Check the door locking pin for free movement. To do so, press in the door locking pin (see fig. 3/3).</p> <p>Upon repeated occurrence, inform your stockist. See also Fault 35.</p>   |
| Fault 14: No feed water              | <p>This warning will be displayed <u>after</u> a program start.</p>   | <p>See warning text <b>Warning no feed water</b>.</p>  |
| Fault 21: Pre-heating                | <p>The monitoring time between activation of the pre-heating</p>  | <p>On repeated occurrence select option <b>Automatic pre-heating No</b></p>  |

| Malfunction message                                 | Possible cause  | What you can do   |
|---|---|---|
|   | and the temperature being reached has been exceeded. The pre-heating temperature was exceeded.  | (see page 19 Selecting automatic pre-heating) and notify specialist dealers.  |
| Fault 22: Overheated pre-heating                    | The maximum pre-heating temperature has been exceeded.  | On repeated occurrence select option Automatic pre-heating No (see page 23, Select automatic pre-heating) and your stockist 19<br>Selecting automatic pre-heating) and notify the stockist.   |
| Fault 31: System leak                               | During the program vacuum test the permitted pressure maximum was exceeded (very large leak) after achieving the evacuation pressure.   | Repeat vacuum test, if renewed error message, notify specialist dealers.  |
| Fault 32: Power outage Sterilize the sterile filter | The operating voltage outed after a program start.<br><br>The malfunction message is issued after the operating voltage is restored.<br><br>A power outage during a program already started in over-pressure will lead to a further instruction to sterilize the sterile filter as it has become damp and possibly even affected by germs. Switching off the sterilizer during a current program. | Check all on-site installations. If you are unable to locate a fault, inform MELAG customer services.<br><br>Remove the sterile filter from the rear of the steam sterilizer and change or sterilize it (see page 38, Replacing or sterilizing the sterile filter).<br><br>A running program should only be aborted with the (S) key. (see also page 21, Manual program abort). |
| Fault 34: Sterilization TU1                         | Minimum permissible sterilization temperature has been undercut (temperature sensor 1).   | Operate device with smaller load, possibly carry out vacuum test. Check door seal for wear. Upon repeated occurrence, inform your stockist.   |
| Fault 35: Sterilization TO1                         | Maximum permissible sterilization temperature has been exceeded (temperature sensor 1).   | Perform vacuum test.<br>Upon repeated occurrence, inform your stockist.   |
| Fault 36: Sterilization PU                          | Minimum sterilization pressure has been undercut.   | Operate device with smaller load, possibly carry out Vacuum test.<br>Check door seal for wear.<br>Upon repeated occurrence, inform your stockist.   |
| Fault 51: Sterilization TU2                         | Minimum permissible sterilization temperature has been undercut (temperature sensor 2).   | Operate device with smaller load, possibly carry out Vacuum test.<br>Check door seal for wear.<br>Upon repeated occurrence, inform your stockist.   |
| Fault 52: Sterilization TÛ2                         | Maximum permissible sterilization temperature has been exceeded (temperature sensor 2).   | Perform vacuum test.<br>Upon repeated occurrence, inform your stockist.   |

## Opening the Emergency door during a power failure



### DANGER

**Non compliance can lead to severe burning and injuries.**

Be absolutely sure that the sterilizer is completely relieved from pressure:

- No steam may be permitted to escape between the sterile filter and the reverse side of the sterilizer.
- The sliding closure grip must be easy to manipulate.
- It must be possible to push back the door about 2 mm with only slight pressure.
- Ensure to allow the sterilizer to cool down. Metal parts such as door and chamber can be hot.

If the door cannot be opened, for instance due to a power failure, comply with the safety instructions outlined above and proceed as follows:

1. Switch the sterilizer off at the power switch and pull the power plug from the wall socket.

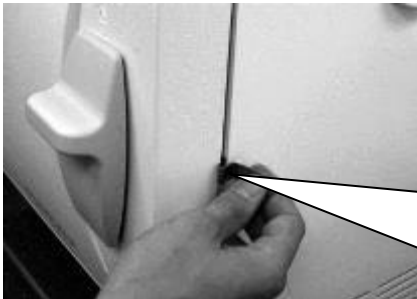

Fig. 7 emergency unlocking of the door

2. If the lever is in the guide, pull it forwards with your right hand. Push the slide locking grip upwards with your other hand.
3. Open the door.

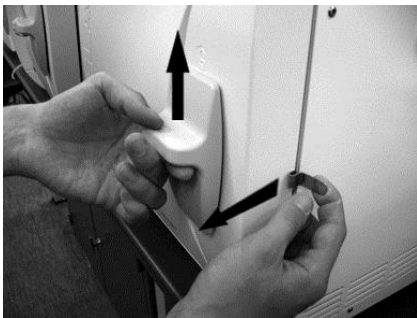

Fig.8 opening the door

## Changing the device fuses

If the device fuses have been tripped, (see p. 9/10), proceed as follows to change:

1. Switch off the sterilizer at the power switch and remove the plug from the socket.
2. Open the door manually in accordance with the section “
- 3.
4. Opening the Emergency door during a power failure”. Unscrew both screw caps of the fuse holder (S. 9/10) at the lower front of the sterilizers with a screwdriver or a coin.

Two replacement fuses are mounted on the door interior (see marking).

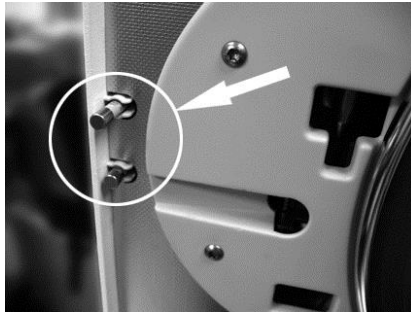

**Fig. 9 Replacement fuses on the door interior**

5. Remove the defective device fuses and insert the new fuses securely in the holder.



**Fig. 10 Fore view, below right**

6. Screw the cap of the fuse holder to the lower sterilizer front.
7. Reconnect the sterilizer plug to the socket and switch on the sterilizer at the power switch.

Should this trigger repeatedly, please inform MELAG customer service/the customer service of your stockist.

# Glossary

## **Aqua dem**

→Demineralized water

## **Aqua dest**

→Distilled water

## **Heat-up phase**

The time required after the sterilizer has been switched on / after the start of a sterilization program, to heat the double jacket steam generator before the sterilization procedure starts. The duration is dependent on temperature at which sterilization takes place.

## **Authorized persons**

Depot technicians or MELAG-specified customer services trained by MELAG.

## **BGV A1**

Specifications from professional associations – the principles of prevention.

## **Bowie & Dick test**

Steam penetration test with a standard test package; described in DIN EN 285; the test is usually recognized in the large-scale sterilization industry.

## **CF card**

Compact Flash-Card; a memory card for digital data.

## **Batch**

Collection of sterilization material which has been processed together in the same sterilization program.

## **Delay in boiling**

Refers to the phenomenon that it is possible under certain circumstances to heat a fluid beyond its boiling point without them boiling. This represents an unstable state; even low-level agitation can produce a large bubble within the shortest period, which expands explosively.

## **Demineralized water**

Water without the minerals usually found in normal spring or tap water; is produced through ion exchange of normal tap water. Used here as feed water.

## **Feed water**

Is required for the creation of water steam for the sterilization; typical values for the water quality according to DIN EN 285 or DIN EN 13060 – Appendix C.

## **Distilled water**

From the Latin aqua destillata; also referred to as aqua dest; water which to a great extent is free from salts, organic material and micro-organisms, is produced from normal tap water or pre-cleaned water through the process of distillation (evaporation and subsequent - condensation). Used here as feed water.

## **DGSV**

Deutsche Gesellschaft für Sterilgutverordnung (German Association for the Sterilized Equipment Ordinance). The DSGV training centres are specified in DIN 58946, part 6 as "Requirements of personnel".

## **DIN 58953**

Standard – sterilisation, sterile equipment supply.

## **DIN EN 867-5**

Standard – non-biological systems for use in sterilizers – part 5: The determination of indicator systems and test bodies for the performance test of small sterilizers of the type B and type S.

## **DIN EN 868-8**

Standard – packaging materials and systems for medical products requiring sterilization.

## **DIN EN ISO 11140-1**

Standard – the sterilization of products for use in medical treatment – chemical indicators – part 1: General requirements.

## **DIN EN ISO 11607-1**

Standard – materials requirements, Sterile barrier systems and packaging systems; this standard represents the result of the harmonization of EN 868 part 1 and the international standard DIN EN ISO 11607.

## **DIN EN 13060**

Standard – Small steam sterilizers.

## **DIN EN 285**

Standard – Sterilization – Steam sterilizers – Large sterilizers.

Dynamic pressure test of the sterilization chamber  
Serves to verify that the rate of the change of pressure occurring in the sterilization chamber during a sterilization cycle does not exceed a certain value, which could lead to damage of the wrapping material [DIN EN 13060].

## **Dynamic pressure test of the sterilization chamber**

Serves to prove that the rate of pressure variations during a sterilization cycle does not exceed a particular value which could result in the damage of the packaging material. [DIN EN 285].

## **Single wrapping**

Wrapped once e.g. instruments sealed in foil – in opposition to: Multiple wrapping.

## **Evacuation**

Creation of a vacuum in a vessel.

## **Fractionated vacuum procedure**

Technical procedure in steam sterilization; the repeated evacuation of the sterilization chamber in alternation with steam injection.

## **FTP**

(File Transfer Protocol) is a data transmission procedure serving to transport data from the internet. This data can include programs, files or even information. Special FTP programs (FTP clients) serve to load the data onto a server (upload).

## **Instruments with narrow lumen**

An article open on one side to which the following applies:

$1 \leq L/D \leq 750$  and  $L \leq 1500$  mm or an article with an opening on both sides which is:

$2 \leq L/D \leq 1500$  and  $L \leq 3000$  mm and which does not correspond to a hollow body article B

L...length of hollow body article

D...Diameter of hollow body article [DIN EN 13060]

## **Mixed loads**

Wrapped and unwrapped sterilization material within a single load.

## **Hollow body A**

→Instruments with narrow lumen

## **Hollow body B**

→Simple hollow instruments



**Initialization**

Creating a specific starting situation of the software upon starting.

**Condensate**

Fluid (e.g. water) produced by the cooling of and resultant separation from the vaporous state.

**Corrosion**

The chemical alteration or destruction of metal materials by water and chemicals.

**Contamination**

Here: the impurification of the sterilizer load through undesirable or damaging materials.

**Empty chamber test**

Test run without a load, performed to assess the performance of a sterilizer without the influence of a load; facilitating verification of the temperatures maintained in comparison to the temperatures set [DIN EN 285].

**Conductivity**

Is the reciprocal value of electrical resistance; measured in micro-Siemens / centimetre ( $\mu\text{S}/\text{cm}$ ); the greater the amount of dissolute matter in the water, the better it can conduct electrical current and thus the higher its conductivity.

**Conductivity measurement**

Conductivity measurement. Measurement of the conductivity.

**Air leakage- verification of the air leakage**

Verification of the leakage serves to prove that the volume of air ingress in the sterilization chamber during the vacuum phase does not exceed a value which would prevent steam penetration of the sterilizer load and that the air leakage does not cause the possible contamination of the sterilizer load during the drying phase.

**Solid**

Without hollows or gaps, solid, compact, closed.

**Massive load – verification of a massive load**

Serves to prove that the necessary sterilization conditions have been reached within the entire load with the values set in the control. The load must represent the largest weight of massive instruments designed for sterilization in a sterilizer in accordance with DIN EN 285.

**Multiple wrapping**

E.g. wrapped instruments sealed in a double layer of film or wrapped in film and placed in an additional container or a container wrapped in textiles.

**MPBetrieb V**

MPBetriebV regulation covering the installation, operation, application and maintenance of medical products according to § 3 of the Medical Devices Directive with the exception of medical products for clinical evaluation or performance evaluation.

**Standard conform**

Satisfies all relevant standards.

**Porous**

Permeable for fluids and air e.g. textiles.

**Porous small components**

Made of materials which are able to absorb fluids.

**Porous partial load – test of porous partial load**

Serves to prove that the values set on the control allow steam to enter the pre-determined test package quickly and equally [DIN EN 13060].

**Porous full load – test of porous full load**

Serves to prove that the values set on the control satisfy the necessary sterilization conditions in porous loads with a maximum mass for which the sterilizer is designed in accordance with DIN EN 285 .

**Process evaluation system**

Also known as the self-monitoring system – observes itself, compares the various sensors during a current program.

**Self monitoring system**

Process evaluation system.

**Separate steam production**

The steam generator is located outside the sterilization chamber. The sterilization chamber is protected from overheating in this way.

**Simple hollow items**

An article open on one side to which the following applies:

$1 \leq L/D \leq 5$  and  $D \geq 5$  mm or an article with an opening on both sides which is:

$2 \leq L/D \leq 10$  and  $D \geq 5$  L...length of hollow article

D...diameter of hollow article [DIN EN 13060]

**Sterile barrier system**

Steriebarrier system: a closed minimum packaging which prevents the entrance of microorganisms e.g. through sealing bags, sealed and re-usable containers and folded sterilization towels etc.

**Sterilized equipment**

Also referred to as a batch: a load which has already been sterilized, i.e. is sterile.

**Sterilization chamber**

The interior of a sterilizer, accommodates the sterilizing material.

**Sterilization material**

Unsterile, sterilizable material which is still to be sterilized.

**TCP**

Transmission control protocol: refers to a standard protocol for connecting computers and networks.

**Vacuum**

In common parlance, an area devoid of all material in the technical sense: volumes with a reduced gas pressure (at least air pressure).

**Vacuum drying**

Gentle drying: the drying load is subject to under-pressure. This reduces the boiling point and thus leads to evaporation even at low temperatures.

**VDE**

Verband der Elektrotechnik, Elektronik und Informationstechnik e.V. (German: The Association of Electrotechnology, Electronics and Information Technology).

**Soft sterilization packaging**

E.g. a paper bag or transparent sterilization packaging.



## Technical Data

| Model name                                    | Vacuklav 23 B+   | Vacuklav 31 B+      |
|---|--|---------------------|
| Device dimensions (HxWxD)                     | 49 x 42.5 x 75.5 cm  | 49 x 42.5 x 61,5 cm |
| Sterilization chamber (diam x depth)          | Ø 25 cm x 45 cm  | Ø 25 cm x 35 cm     |
| Volume of the sterilization chamber           | 22 litres  | 17 litres           |
| Volume of the storage tank                    | Feed water (right chamber) 5 litres (c.7 cycles);<br>waste water side (left chamber): 3 litres   |                     |
| Weight (empty)                                | 50 kg  | 45 kg               |
| Electrical power                              | 2100 W   |                     |
| Electrical connection                         | A 220 -240V circuit (max. voltage range 207-253V) and<br>50/60 Hz building-side recommended: separate circuit with 16 A<br>fuse, an additional FI switch 30 mA |                     |
| Noise emission                                | Sound pressure level @1m space, < 65db (A)   |                     |
| Waste heat (with max. solid load)             | 0.9 kWh  |                     |
| Ambient temperature                           | 5-40 °C (recommended max. 25 °C)   |                     |
| Relative humidity                             | 80% at 31 °C, decreasing in a linear fashion up to a relative<br>humidity of 50% at 40 °C  |                     |
| Max. altitude                                 | 2000 m   |                     |
| Length of power cable                         | 1.35 m   |                     |
| Feed water quality                            | Distilled or demineralized feed water in accordance with<br>DIN EN 13060, Appendix C (with central demineralization<br>system max. conductivity 5 µ            |                     |
| CE mark                                       | CE 0197, CE 0035   |                     |
| Degree of protection<br>(following IEC 60529) | IP20   |                     |

## Accessories

|  | Article   | Order no.*     |                |
|--|---|----------------|----------------|
|  |   | Vacuklav 23 B+ | Vacuklav 31 B+ |
| Tray mounts  | A for 5 trays or 3 standard-tray cassette                               | 40244          | 40233          |
|  | Bracket >B< for 4 standard tray cassettes                               | 40224          | 40234          |
|  | D for two tall cassettes of 4 trays                                     | 46840          |                |
| Sterilization container with a single-use paper filter in accordance with DIN EN 868-8 | 15K depth / width / height in cm: 18/ 12/4.5                            | 01151          |                |
|  | 15M depth / width / height in cm: 35/ 12/4.5                            | 01152          |                |
|  | 15G depth / width / height in cm: 35/ 12/8                              | 01153          |                |
|  | 17K depth / width / height in cm: 20/ 14/5                              | 01171          |                |
|  | 17M depth / width / height in cm: 41/ 14/ 5                             | 01172          |                |
|  | 15M depth / width / height in cm: 14/ 14/ 9                             | 01173          |                |
|  | 23M depth / width / height in cm: 42/ 16/ 6                             | 01231          |                |
|  | 23G depth / width / height in cm: 42/ 16/ 12                            | 01232          |                |
|  | 28M depth / width / height in cm: 32/ 16/ 6                             | 01284          |                |
|  | 28G depth / width / height in cm: 32/ 16/12                             | 01285          |                |
| Swab drums with filter cloth   | 17R diameter/ height in cm: 13/ 10.5                                    | 00174          |                |
|  | 23R diameter/height in mm: 18/ 14                                       | 00233          |                |
| Package holder   | For chamber $\varnothing$ 25 cm x 45 or 35 cm                           | 22420          | 22410          |
| Standard tray cassettes  | depth / width / height in mm: 29/ 19/ 4                                 |                |                |
|  | with filter cloth   | 00289          |                |
|  | without filter cloth  | 00286          |                |
| Trays  | Tray  | 00230          | 00280          |
| Test body system   | MELAcontrol consisting of a Helix test body and 250 indicator strips    | 01080          |                |
|  | MELAcontrol PRO consisting of a Helix test body and 40 indicator strips | 01075          |                |
| Water treatment unit   | MELAdem 40; floor unit mounting   | 01049          |                |
|  | MELAdem 47; floor unit mounting   | 01047          |                |
|  | Upgrade set for the tank drain  | 26695          |                |
| For documentation:   | MELAflash CF-Card printer with CF card and card reader                  | 01039          |                |
|  | MELAprint 42 log printer  | 01042          |                |
|  | MELAnet Box   | 40296          |                |
| Other  | Water stop  | 01056          |                |
|  | Device fuses 16A /gRL   | 57592          |                |
|  | Door seal   | 58512          |                |
|  | Sterile filter  | 20160          |                |

\*All articles listed are available via your specialist stockist



## MELAG Medizintechnik oHG

Geneststraße 6-10  
10829 Berlin  
Germany  
e-mail: [info@melag.de](mailto:info@melag.de)  
Web: [www.melag.de](http://www.melag.de)

Responsible for content: MELAG Medizintechnik oHG

Subject to technical alterations

Date of update: 30.06.2016

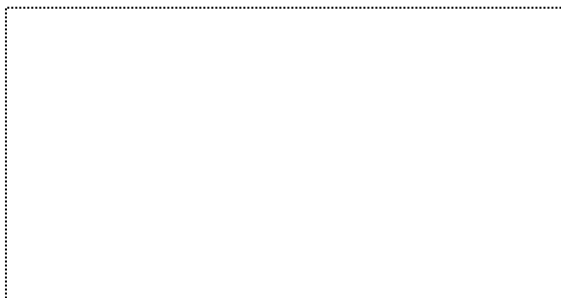

Rev.:13– 16/1284

BA\_EN\_23B+\_31B+\_V13.docx