



Instructions for Use

A-dec 461 Cuspidor with Support Center

Copyright

© 2014 A-dec Inc. All rights reserved.

A-dec Inc. makes no warranty of any kind with regard to this material, including, but not limited to, the implied warranties of merchantability and fitness for a particular purpose. A-dec Inc. shall not be held liable for any errors contained herein or any consequential or other damages concerning the furnishing, performance or use of this material. The information in this document is subject to change without notice. If you find any problems in the documentation, please report them to us in writing. A-dec Inc. does not warrant that this document is error-free.

No part of this document may be copied, reproduced, altered, or transmitted in any form or by any means, electronic or mechanical, including photocopying, recording, or by any information storage and retrieval system, without prior written permission from A-dec Inc.

Trademarks and Additional Intellectual Property Rights

A-dec, the A-dec logo, A-dec 500, A-dec 300, Cascade, Cascade Master Series, Century Plus, Continental, Decade, ICX, ICV, Performer, Preference, Preference Collection, Preference ICC, and Radius are trademarks of A-dec Inc. and are registered in the United States and other countries. A-dec 400, A-dec 200, Preference Slimline, and reliablecreativesolutions are also trademarks of A-dec Inc. None of the trademarks or trade names in this document may be reproduced, copied, or manipulated in any manner without the express, written approval of the trademark owner.

Certain touchpad symbols are proprietary to A-dec Inc. Any use of these symbols, in whole or in part, without the express written consent of A-dec Inc., is strictly prohibited.

Regulatory Information

Regulatory information mandated by agency requirements is provided in the *Regulatory Information, Specifications, and Warranty* document (p/n 86.0221.00), which is available in the Document Library at www.a-dec.com.

Product Service

Product service is available through your local authorized A-dec dealer. For service information, or to locate an authorized dealer, contact A-dec at 1.800.547.1883 in the USA and Canada or 1.503.538.7478 worldwide, or visit www.a-dec.com.

Content Map

Bowl Rinse 2



Bowl Cleaning 4



Water Bottle 5

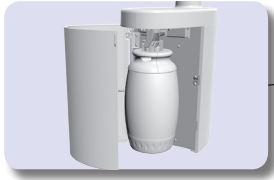

Cupfill 2



Cuspidor Controls 2



Flow Adjustment 3



Operate / Adjust	2
Clean / Maintain.....	4
Specifications and Warranty.....	7



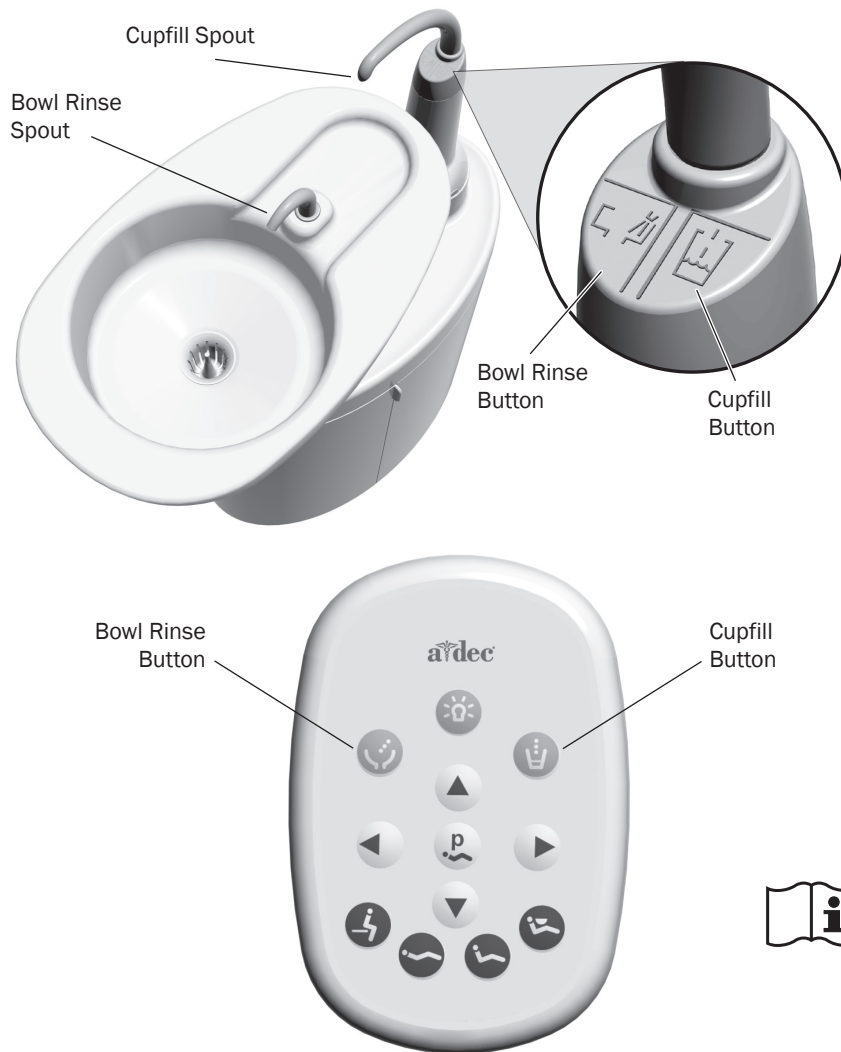

Operate / Adjust

Cuspidor Functions



Bowl Rinse and Cupfill

Use the buttons under the cupfill spout or on the touchpad to control the bowl rinse and cupfill functions. The buttons support both programmed and manual operation.

Button	Description and Factory Presets
 or 	<p>Bowl Rinse Operation:</p> <ul style="list-style-type: none"> Press and release the bowl rinse button for a timed operation. The factory preset is a 30 second rinse. Press and release the bowl rinse button twice in less than two seconds to activate the continuous operation mode. Press and release the button again to end the continuous mode. Press and hold the bowl rinse button for manual operation.
 or 	<p>Cupfill Operation:</p> <ul style="list-style-type: none"> Press and release the cupfill button for a timed operation. The factory preset is a 2.5 second fill. Press and hold the cupfill button for manual operation.

Note: Touchpad symbols are proprietary to A-dec Inc.



For complete instructions on delivery system touchpad operation, see your delivery system Instructions For Use.

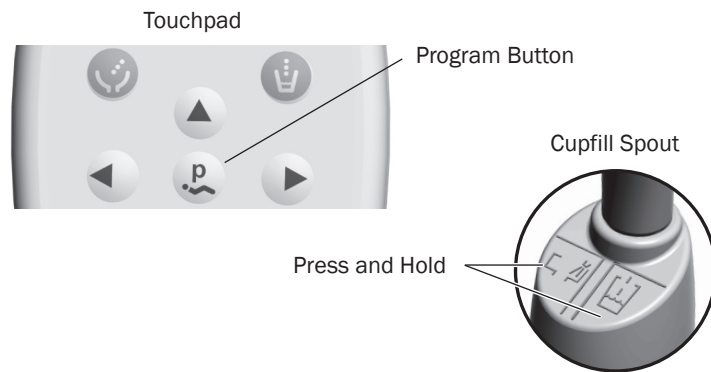

Customize Bowl Rinse or Cupfill Timing

To reprogram the timed bowl rinse or cupfill functions:

1. Press **P** on the touchpad, or press and hold the cupfill and bowl rinse buttons under the cupfill spout. Release the button(s) when you hear one beep.
2. Within five seconds, press and hold the cupfill or bowl rinse button for the desired time.
3. Release the button. Three beeps confirm that the program has changed.

Cuspidor Stop Switch

If an object gets caught under the cuspidor bowl as the chair is lowered, a stop switch will interrupt the chair motion to prevent damage. If the object becomes lodged, press Base Up (**▲**) on the footswitch or touchpad to remove the object and resume normal operation. See your dental chair Instructions for Use.



Bowl Rinse Flow Adjustment

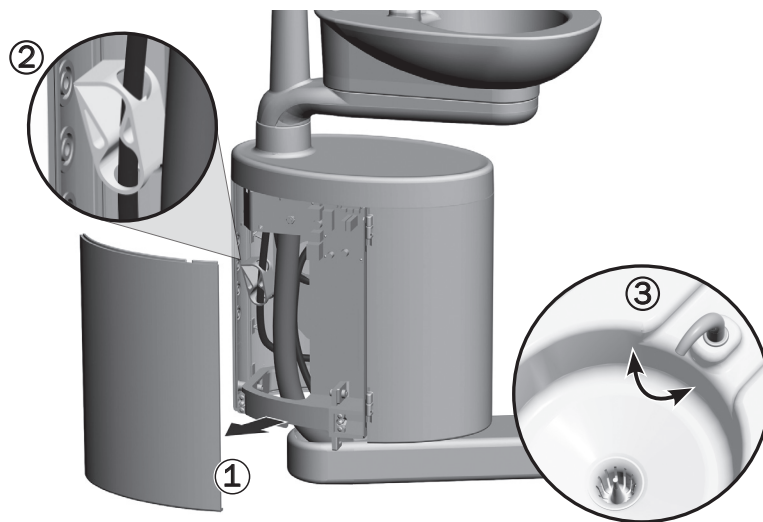

The bowl rinse function should provide enough water to completely rinse the cuspidor bowl. If the flow is not sufficient, an adjustment can be made inside the support center:

1. Remove the side cover from the support center by pulling the lower edges of the cover out.
2. With the bowl rinse on, squeeze the pinch valve to reduce the flow. Release the valve to increase the flow.
3. For the best rinsing action, adjust the flow pattern by rotating the bowl rinse spout.

Clean / Maintain

Cuspidor and Drain



Spouts and Bowl

The contoured spouts and smooth bowl of the cuspidor provide for quick and easy cleaning. Remember to empty and clean the bowl screen every time you clean the cuspidor.



CAUTION Do not remove the spouts when cleaning the cuspidor. This will help prevent cleaning solutions from damaging the equipment and contaminating the cupfill water.



CAUTION Do not empty the solids collector screen or bowl screen into the cuspidor. Doing so could plug the cuspidor drain. Dispose of the contents in an appropriate biohazard container according to the regulations specific to your location. After cleaning, always install the bowl screen in the cuspidor bowl to prevent debris from plugging the drain.

Gravity Drain Tubing

At the end of each day, flush the cuspidor to remove debris from the flexible drain tubing. If the cuspidor is not flushed regularly, debris may build up and impair draining. To flush the cuspidor, run the bowl rinse for about 60 seconds.

Maintenance Parts

For replacement cuspidor bowl screens, order p/n 75.0035.03.

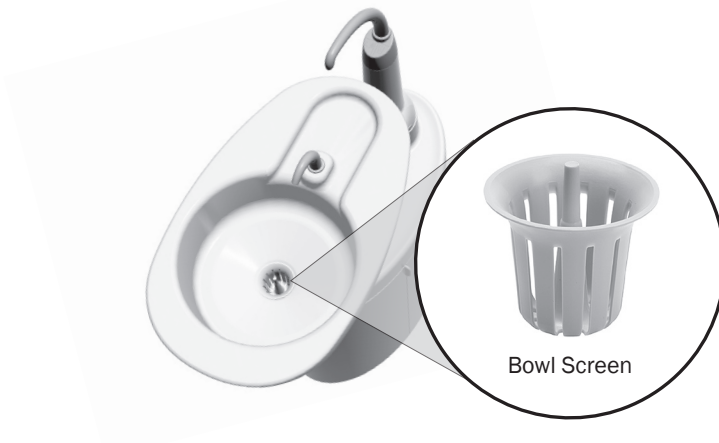

Barrier Protection

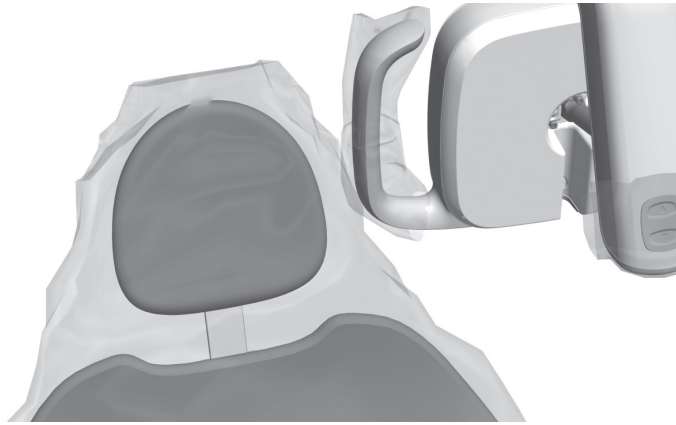

DANGER If you use barriers, always replace the barrier film after each patient.



A-dec recommends barrier protection for all applicable touch and transfer surfaces. Touch surfaces are areas that come into contact with hands and become potential cross-contamination points during dental procedures. Transfer surfaces are areas that come into contact with instruments and other inanimate objects.

In the USA, barriers must be produced under the Current Good Manufacturing Practice (CGMP) as specified by the U.S. Food and Drug Administration (USFDA). For regions outside the USA, refer to the medical device regulations specific to your location.



IMPORTANT For recommendations on cleaning and chemical disinfection of touch and transfer surfaces (where barrier protection is not applicable or when barriers are compromised), please see the *A-dec Equipment Asepsis Guide* (p/n 85.0696.00).

Self-Contained Water System



Delivery Arm



Support Center



The self-contained water system includes a 2-liter, quick-disconnect water bottle that mounts to the delivery system arm or support center and supplies water to instruments and the cuspidor cupfill. It also provides an easy way to control the quality of your treatment water.

To properly maintain your system and water quality, A-dec recommends that you use an A-dec ICX® tablet with every water bottle refill.



IMPORTANT Follow the instructions that appear on the ICX packaging. For complete details on water usage in your A-dec system, see the *A-dec Self-Contained Water System Instructions For Use* (p/n 86.0609.00) and *Waterline Maintenance Guide* (p/n 85.0983.00).

Utilities and Shutoff Valves

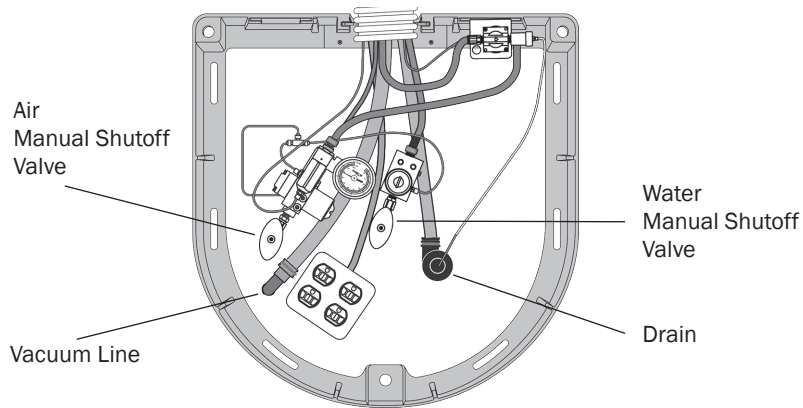

CAUTION When removing or replacing covers, take care not to damage any wiring or tubing. Verify that the covers are secure after replacing them.

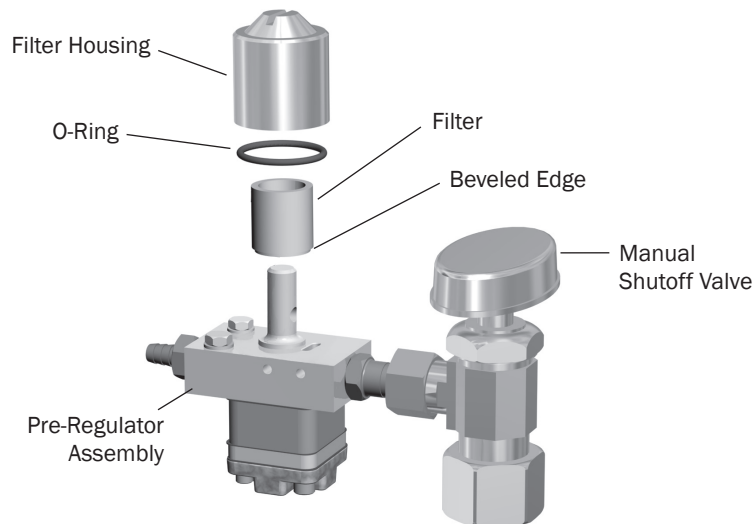

The utilities for A-dec chair-mounted delivery systems are located in the contoured floor box under your chair. To access, lift the cover up and off the floor box frame.

The manual shutoff valves control the air and water to the system. To prevent leaks, leave these valves fully open (turned counterclockwise), except when your system is being serviced.

Air and water pass through separate filters before entering the regulators. Replace these filters when they become clogged and restrict flow.

To check for a clogged water filter:

1. Turn on the master toggle.
2. While watching the cuspidor, press the bowl rinse button. If the bowl rinse water pressure fades or if the water flow stops, replace the water filter.

To replace the filter:

1. Turn off the master toggle and close the shutoff valves (turn clockwise).
2. Bleed the system of air and water pressure by operating the syringe buttons until air and water no longer flow.
3. Using a standard screwdriver, remove the filter housing from the water pre-regulator assembly and remove the filter.
4. Replace the filter if it is clogged or discolored. Install the filter with the beveled edge facing the manifold.



CAUTION To ensure proper operation, install the filter with the beveled edge facing the manifold.

5. Open the shutoff valves, turn on the master toggle, and operate the bowl rinse to remove air from the waterline.

Specifications



Minimum Air and Water Service Requirements

Air: 70.80 L/min (2.50 scfm) at 551 kPa (80 psi)

Water: 5.68 L/min (1.50 gpm) at 276 kPa (40 psi)



IMPORTANT For electrical specifications, identification of symbols, and other regulatory requirements, see the *Regulatory Information, Specifications, and Warranty* document (p/n 86.0221.00), which is available in the Document Library at www.a-dec.com.



NOTE Specifications are subject to change without notice. Requirements may vary depending on your location. For more information, contact your authorized A-dec dealer.

Warranty

Warranty information is provided in the *Regulatory Information, Specifications, and Warranty* document (p/n 86.0221.00), which is available in the Document Library at www.a-dec.com.



A-dec Headquarters

2601 Crestview Drive
Newberg, Oregon 97132
United States
Tel: 1.800.547.1883 within USA/CAN
Tel: +1.503.538.7478 outside USA/CAN
Fax: 1.503.538.0276
www.a-dec.com

A-dec Australia

Unit 8
5-9 Ricketty Street
Mascot, NSW 2020
Australia
Tel: 1.800.225.010 within AUS
Tel: +61.(0).2.8332.4000 outside AUS

A-dec China

A-dec (Hangzhou) Dental Equipment Co., Ltd.
528 Shunfeng Road
Qianjiang Economic Development Zone
Hangzhou 311106
Zhejiang, China
Tel: +1.503.538.7478

A-dec United Kingdom

EU Authorized Representative
Austin House, 11 Liberty Way
Nuneaton, Warwickshire CV11 6RZ
England
Tel: 0800.ADEC.UK (2332.85) within UK
Tel: +44.(0).24.7635.0901 outside UK



86.0374.00 Rev B
Copyright 2014 A-dec Inc.
All rights reserved.